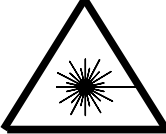

SCHMIDT 1 TAIWAN

**RICOH FAX2000L
SERVICE MANUAL**

30 November, 1999
Subject to change

Important Safety Notices

DANGER INVISIBLE LASER RADIATION WHEN OPEN AVOID DIRECT EXPOSURE TO BEAM	
CAUTION INVISIBLE LASER RADIATION WHEN OPEN AVOID EXPOSURE TO BEAM	VORSICHT UNSICHTBARE LASERSTRAHLUNG, WENN ABDECKUNG GEOFFNET NICHT DEM STRAHL AUSSETZEN

H545R500.WMF

Laser Safety

⚠ WARNING FOR LASER UNIT
This machine contains a laser beam generator. Laser beams can cause permanent eye damage. Do not open the laser unit or look along the laser beam path while the main power is on.

Lithium Batteries (Memory Back-up)

⚠ CAUTION
The danger of explosion exists if a battery of this type is incorrectly replaced. Replace only with the same or an equivalent type recommended by the manufacturer. Discard used batteries in accordance with the manufacturer's instructions.

TABLE OF CONTENTS

1. OVERALL MACHINE INFORMATION	1-1
1.1 SPECIFICATIONS	1-1
1.2 FEATURES.....	1-3
1.3 COMPONENT LAYOUT	1-7
1.3.1 MECHANICAL COMPONENTS.....	1-7
1.3.2 ELECTRICAL COMPONENTS	1-9
1.4 OVERALL MACHINE CONTROL	1-13
1.5 VIDEO DATA PATH	1-14
1.5.1 TRANSMISSION.....	1-14
1.5.2 RECEPTION.....	1-15
1.5.3 COPYING	1-16
1.6 POWER DISTRIBUTION.....	1-17
1.6.1 DISTRIBUTION DIAGRAM.....	1-17
1.6.2 MEMORY BACK-UP CIRCUIT	1-18
2. DETAILED SECTION DESCRIPTIONS.....	2-1
2.1 SCANNER	2-1
2.1.1 MECHANISMS.....	2-1
2.1.2 JAM CONDITIONS	2-3
2.2 PRINTING.....	2-4
2.2.1 PRINTING PROCESS - OVERVIEW	2-4
2.2.2 OPC DRUM	2-5
2.2.3 CHARGE	2-5
2.2.4 LASER EXPOSURE	2-6
2.2.5 TONER SUPPLY	2-8
2.2.6 DEVELOPMENT.....	2-10
2.2.7 PAPER FEED	2-14
2.2.8 REGISTRATION	2-19
2.2.9 TRANSFER AND SEPARATION	2-21
2.2.10 CLEANING.....	2-22
2.2.11 FUSING	2-23
2.3 SYSTEM FEATURES.....	2-27
2.3.1 ENERGY SAVER MODES	2-27
2.3.2 AUTOMATIC SERVICE CALLS.....	2-29
2.3.3 SEP/SUB CODING	2-30
2.3.4 PAGE SEPARATION AND DATA REDUCTION.....	2-33
2.3.5 MEMORY RECEPTION CONDITIONS	2-35
2.3.6 V.8/V.34 PROTOCOL.....	2-36
2.3.7 BLANK SHEET DETECTION.....	2-38
2.4 PCBS.....	2-39
2.4.1 FCU	2-39
2.4.2 PSU	2-41
2.4.3 NCU (USA/TAIWAN)	2-42

3. INSTALLATION.....	3-1
3.1 INSTALLING THE MACHINE	3-1
3.2 INITIAL PROGRAMMING.....	3-1
3.3 INSTALLING OPTIONAL UNITS	3-1
4. SERVICE TABLES AND PROCEDURES	4-1
4.1 SERVICE LEVEL FUNCTIONS	4-1
4.1.1 BIT SWITCH PROGRAMMING (FUNCTION 01).....	4-1
4.1.2 SYSTEM PARAMETER LIST (FUNCTION 02).....	4-2
4.1.3 ERROR CODE DISPLAY (FUNCTION 03).....	4-2
4.1.4 SERVICE MONITOR REPORT (FUNCTION 04).....	4-2
4.1.5 GROUP 3 PROTOCOL DUMP (FUNCTION 05)	4-2
4.1.6 PC PROTOCOL DUMP (FUNCTION 05)	4-3
4.1.7 RAM DISPLAY/REWRITE (FUNCTION 06).....	4-3
4.1.8 RAM DUMP (FUNCTION 06).....	4-3
4.1.9 COUNTER DISPLAY/REWRITE (FUNCTION 07).....	4-4
4.1.10 NCU PARAMETERS (FUNCTION 08).....	4-5
4.1.11 MODEM TEST (FUNCTION 08)	4-5
4.1.12 DTMF TONE TEST (FUNCTION 08)	4-5
4.1.13 V.8 MODEM TEST (FUNCTION 08).....	4-6
4.1.14 V.34 MODEM TEST (FUNCTION 08).....	4-6
4.1.15 RINGER TEST (FUNCTION 08)	4-7
4.1.16 OPERATION PANEL TEST (FUNCTION 09)	4-7
4.1.17 LED ARRAY TEST (FUNCTION 10).....	4-7
4.1.18 ADF TEST (FUNCTION 10).....	4-8
4.1.19 PRINTER TEST PATTERNS (FUNCTION 11)	4-8
4.1.20 PRINTER MECHANISM TEST - FREE RUN (FUNCTION 11)	4-8
4.1.21 RAM TESTS (FUNCTION 12).....	4-9
4.1.22 SOFTWARE DOWNLOAD (FUNCTION 12).....	4-9
4.1.23 SOFTWARE UPLOAD (FUNCTION 12)	4-10
4.1.24 SRAM DATA DOWNLOAD (FUNCTION 12)	4-11
4.1.25 SERVICE STATION FAX NUMBER (FUNCTION 13)	4-12
4.1.26 SERIAL NUMBER (FUNCTION 14).....	4-12
4.2 BIT SWITCHES	4-13
4.2.1 SYSTEM SWITCHES	4-13
4.2.2 SCANNER SWITCHES	4-21
4.2.3 PRINTER SWITCHES	4-22
4.2.4 COMMUNICATION SWITCHES	4-25
4.2.5 G3 SWITCHES	4-30
4.3 NCU PARAMETERS	4-37
4.4 DEDICATED TRANSMISSION PARAMETERS	4-46
4.4.1 PROGRAMMING PROCEDURE	4-46
4.4.2 PARAMETERS	4-47
4.5 SERVICE RAM ADDRESSES	4-49

5. PREVENTIVE MAINTENANCE	5-1
5.1 SPECIAL TOOLS AND LUBRICANTS	5-1
5.2 PM TABLE	5-1
6. REPLACEMENT AND ADJUSTMENT.....	6-1
6.1 EXTERIOR	6-1
6.1.1 TOP COVER.....	6-1
6.1.2 OPERATION PANEL	6-2
6.2 ADF.....	6-2
6.2.1 FEED ROLLER ASSEMBLY	6-2
6.2.2 SEPARATION ROLLER	6-3
6.3 SCANNER	6-3
6.3.1 SCANNER UNIT DISASSEMBLY	6-3
6.3.2 SCANNER MOTOR	6-4
6.3.3 R1/R2 ROLLERS.....	6-5
6.3.4 CONTACT IMAGE SENSOR ASSEMBLY.....	6-5
6.3.5 SCANNER UNIT	6-6
6.4 LASER PRINTING COMPONENTS	6-7
6.4.1 LASER UNIT.....	6-7
6.5 DEVELOPMENT.....	6-9
6.5.1 TRANSFER ROLLER	6-9
6.6 FUSING	6-10
6.6.1 FUSING UNIT	6-10
6.6.2 THERMISTOR	6-11
6.6.3 HOT ROLLER STRIPPERS.....	6-11
6.6.4 FUSING LAMP AND HOT ROLLER	6-12
6.6.5 PRESSURE ROLLER.....	6-13
6.6.6 THERMOSTAT AND THERMOFUSE.....	6-13
6.7 PCBS.....	6-14
6.7.1 NCU	6-14
6.7.2 PSU	6-14
6.7.3 POWER PACK.....	6-15
6.7.4 FCU	6-15
6.8 PAPER FEED	6-16
6.8.1 SEPARATION PAD	6-16
6.8.2 PAPER FEED UNIT ASSEMBLY AND PAPER FEED MOTOR	6-17
6.8.3 PAPER END SENSOR AND REGISTRATION SENSOR.....	6-18
6.8.4 PAPER FEED ROLLER/CLUTCH AND TRANSPORT ROLLER...	6-18
6.9 OTHERS.....	6-19
6.9.1 INTERLOCK SWITCHES	6-19
6.9.2 MAIN MOTOR.....	6-20
6.9.3 REGISTRATION ROLLER.....	6-21
6.9.4 TONER END SENSOR.....	6-22
6.10 PAPER FEED UNIT (OPTIONAL)	6-23
6.10.1 TRANSPORT ROLLER	6-23
6.10.2 PAPER FEED ROLLER AND PAPER FEED CLUTCH	6-23
6.10.3 CONNECTOR.....	6-24
6.11 IMAGE ADJUSTMENT	6-25

6.11.1 OVERVIEW	6-25
6.11.2 SCANNER PARAMETERS.....	6-26
6.11.3 PRINTER PARAMETERS.....	6-27
6.11.4 SCANNER VIDEO PROCESSING PARAMETERS.....	6-29
7. TROUBLESHOOTING.....	7-1
7.1 COPY QUALITY TROUBLESHOOTING	7-1
7.1.1 BLANK COPIES.....	7-2
7.1.2 BLACK COPIES.....	7-2
7.1.3 DIRTY BACKGROUND	7-3
7.1.4 UNEVEN IMAGE DENSITY	7-4
7.1.5 VERTICAL BLACK LINES	7-5
7.1.6 HORIZONTAL BLACK LINES.....	7-6
7.1.7 VERTICAL WHITE LINES	7-7
7.1.8 HORIZONTAL WHITE LINES.....	7-8
7.1.9 BLACK DOTS/SPOTS	7-9
7.1.10 WHITE SPOTS IN BLACK IMAGE AREAS	7-10
7.1.11 FAINT COPIES.....	7-11
7.1.12 VERTICAL BLACK BAND.....	7-13
7.1.13 UNFUSED COPIES	7-14
7.1.14 GHOST IMAGE.....	7-14
7.1.15 TONER ON THE BACK OF THE PRINTER PAPER	7-15
7.1.16 INCORRECTLY ALIGNED OUTPUT (DATA SHIFTED TO THE RIGHT OR LEFT)	7-15
7.1.17 INCORRECTLY ALIGNED OUTPUT (IMAGE SHIFTED VERTICALLY)/REDUCED IMAGE	7-16
7.2 MECHANICAL PROBLEMS	7-17
7.2.1 ADF/SCANNER	7-17
7.2.2 PRINTER	7-20
7.3 SERVICE CALL CONDITIONS.....	7-24
7.4 ERROR CODES	7-26
7.5 ELECTRICAL COMPONENT DEFECTS.....	7-34
7.5.1 DEFECTIVE SENSOR TABLE	7-34
7.5.2 BLOWN FUSE TABLE	7-34

1. OVERALL MACHINE INFORMATION

1.1 SPECIFICATIONS

Type

Desktop transceiver

Circuit

PSTN, PABX

Connection

Direct couple

Document Size

Length:

105 - 364 mm

Up to 1.2 m, manually assisted

Width:

148 - 257 mm

Thickness:

0.05 to 0.2 mm

(equivalent to 50 - 80 g/m²)

Document Feed

Automatic feed, face down

ADF Capacity

30 sheets (using A4 size 70 g/m² paper)

15 sheets (using B4 size 70 g/m² paper)

Scanning Method

Contact image sensor, with xenon lamp

Maximum Scan Width

256 mm ± 0.25%

(Effective scan width: 250 mm)

Scan Resolutions

Main scan: 8 dots/mm [203 dpi]

Sub scan:

Standard - 3.85 lines/mm [98 dpi]

Detail - 7.7 lines/mm [196 dpi]

Fine - 15.4 lines/mm [392 dpi]

Memory Capacity

ECM: 128 Kbytes

SAF:

Standard: 512 KB (40 pages/ITU-T #1)

With 1 MB option: 120 pages

With 2 MB option: 200 pages

Compression

MH, MR, MMR, and SSC

SAF storage for memory TX: MMR and/or raw data

Protocol

Group 3 with ECM

Modulation

V.34, V.33 (Ricoh mode only),

V.17 (TCM), V.29 (QAM), V.27ter

(PHM), V.21 (FM)

Data Rate (BPS)

33,600/31,200/28,800/26,400/24,000/

21,600/19,200/16,800/14,400/12,000/

9600/7200/4800/2400

I/O Rate

With ECM: 0 ms/line

Without ECM: 2.5, 5, 10, 20, or 40 ms/line

Transmission Time

3 seconds at 28,800 bps: Measured with G3 ECM using memory for an ITU-T #1 test document (Slerexe letter) at standard resolution

Printing System

Laser printing, plain paper, dry toner

Printing Time

6 ppm for letter-size paper

Paper Size and Capacity

Standard Cassette: 250 sheets

Letter, Legal, A4, A5 sideways, F4

Paper Feed Unit (Optional):

500 sheets: Letter, Legal, A4,

A5 sideways, F4

Maximum Printing Width

208 mm [8.1 ins]

Print Resolutions

Main scan: 16 dots/mm [406 dpi]

Sub scan: 15.4 lines/mm [392 lpi]

Power Supply

110 ± 20 Vac, 60 ± 1 Hz

Power Consumption (Max)

Standby: Minimum 2 W; Normal 10 W

Transmit: 31 W

Receive: 889 W

Copying: 898 W

Operating Environment

Temperature: 15 - 25 °C

Humidity: 30 - 70 %Rh

Dimensions (W x D x H)

399 x 730 x 323 mm

Including trays (Maximum dimensions)

Weight

Approx. 12.5 kg [27.6 lbs.]

Including cartridge and trays.

1.2 FEATURES

KEY: O = Used, X = Not Used,
A = With optional memory only
B = With optional paper feed unit only

Equipment	
ADF	O
Book scan	X
Bypass feed: 1 sheet	X
Optional cassette: 100 sheets	X
Optional cassette: Universal	O
Optional paper feed unit	B
Cabinet	X
Mechanical counter	X
Cutter	X
Handset	X
Hard disk	X
Manual feed mechanism	X
Marker (Stamp)	X
Monitor speaker	O
Optional memory	O
Optional printer interface	X

Video Processing Features	
Automatic image density selection	X
Contrast	O
Halftone (Basic & Error diffusion)	O
JBIG compression	X
MTF	O
Reduction before TX	X
Scanning resolution	O
Smoothing to 16 x 15.4 l/mm	O

Communication Features - Auto	
AI short protocol	O
Automatic fallback	O
Automatic redialing	O
Confidential reception	O
Dual access	O

Communication Features - Auto	
Resolutions available for reception	
Fine	X
Super fine	X
Substitute reception	O
V.34 communication	O

Communication Features - User Selectable	
Action as a transfer broadcaster	X
AI Redial (last ten numbers)	O
Answering machine interface	O
Authorized Reception	O
Auto dialing (pulse or DTMF)	O
Auto document	X
Automatic voice message	X
Batch transmission (max 35 files)	O
Broadcasting	O
Chain dialing	O
Communication result display	X
Confidential ID override	X
Confidential transmission	X
Direct fax number entry	O
Economy transmission	X
Fax on demand	X
Forwarding	O
Groups (5 groups)	O
Hold	X
ID transmission	X
Immediate redialing	O
Immediate transmission	O
ISDN	X
Keystroke programs	O
Memory transmission	O
Multi-step transfer	X
OMR	X
On hook dial	O
Ordering toner	X
Page count	O
Page separation mark	O

Communication Features - User Selectable	
Parallel memory transmission	X
Personal codes	O
Personal codes with conf. ID	O
Partial image area scanning	X
Polling reception	O
Polling transmission	X
Polling tx file lifetime in the SAF	X
PWD (tx only)	O
Quick dial (30 stations)	O
Reception modes (Fax, Tel, Auto)	O
Remote control features	X
Remote transfer	X
Restricted access	X
Secured polling reception	X
Secured polling reception with Stored ID override	X
Send later	O
SEP (tx only)	O
SID (tx only)	O
Silent ringing detection	X
Specified Image area	X
Speed dial (50 stations)	O
SUB (tx only)	O
Telephone directory	O
Tonal signal transmission	O
Transfer request	X
Transmission deadline (TRD)	X
Turnaround polling	X
Two-step transfer	X
Two in one	X
Voice request (immediate TX only)	X

Communication Features - Service Selectable	
AI short protocol	O
Auto-reduction override option	O
Busy tone detection	O
Cable equalizer	O
Closed network (TX and RX)	X

Communication Features - Service Selectable	
Continuous polling reception	X
Dedicated TX parameters	O
ECM	O
EFC	X
Inch-mm conversion	X
Page retransmission times	O
Protection against bad connections	O
Short preamble	X

Other User Features	
Area code prefix	X
Automatic service call	Service
Center mark	O
Checkered mark	X
Clearing a memory file	O
Clearing a polling file	O
Clock	O
Confidential ID	O
Copy mode	O
Copy mode restriction	X
Counters	O
Daylight saving time	O
Destination check	X
Direct entry of names	O
Energy saver (Night timer and standby mode)	O
File retention time	X
File retransmission	X
Function programs	O
ID code	X
Label insertion ("From xxx")	O
Language selection	O
LCD contrast control	X
Memory lock	X
Modifying a memory file	X
Multi-sort document reception	X
Multi-copy mode (up to 99)	O
Own telephone number	O
PC scanner	X
PC fax	X
PC print	X
Print density control	X

Other User Features	
Printing a memory file	O
Quick dial label printing	O
RDS on/off	O
Reception mode switching timer	X
Reception time printing	X
Remaining memory indicator	O
Remote ID	X
Reverse order printing	O
RTI, TTI, CSI	O
Service report transmission	X
Speaker volume control	O
Specified cassette selection	B
Substitute reception on/off	O
Telephone line type	O
Toner saving mode	X
User function keys	O
User parameters	O
Wild cards	O

Reports - Automatic	
Charge control report	X
Communication failure report	O
Communication result report	O
Confidential file report	O
Error report	O
File clear report	X
File reserve report	X
Journal	O
Power failure report	O
Toner cassette order form	X
Transfer result report	X
Transmission result report	O

Reports – User-initiated	
Charge control report	X
File list	O
Group list	O
Journal	O
Personal code list	O
Program list	O
Programmed special numbers list	O
Quick dial / User function list	O

Reports – User-initiated	
Speed dial list	O
Transmission status report	X
User parameter list	O

Service Mode Features	
Back-to-back test	O
Bit switch programming	O
Book mode test	X
Buzzer test	O
Cable equalizer	O
Comm. Parameter display	O
Counter check	O
Country code	O
DTMF tone test	O
Echo countermeasure	O
Effective term of service calls	O
Error code display	O
Excessive jam alarm	O
File transfer (all files)	O
LCD contrast adjustment	X
Line error mark	O
Memory file printout (all files)	O
Modem software download	X
Modem test	O
NCU parameters	O
Operation panel test	O
Periodic service call	O
PM call	O
Printer mechanism test	O
Printer test patterns	O
Programmable attenuation	X
Protocol dump list	O
RAM display/rewrite	O
RAM dump	O
RAM test	O
RDS	O
Ringer test	X
Scanner lamp test	O
Scanner mechanism test	O
Sensor initialization	X
Serial number	O
Service monitor report	O
Service station number	O
Software upload/download	O
SRAM data upload/download	O

Service Mode Features	
System parameter list	O
Technical data on the Journal	O
Thermal head parameters	X

Memory Files

Maximum number of files: 100
Maximum number of stations/file: 100
Maximum number of stations: 200

1.3 COMPONENT LAYOUT

1.3.1 MECHANICAL COMPONENTS

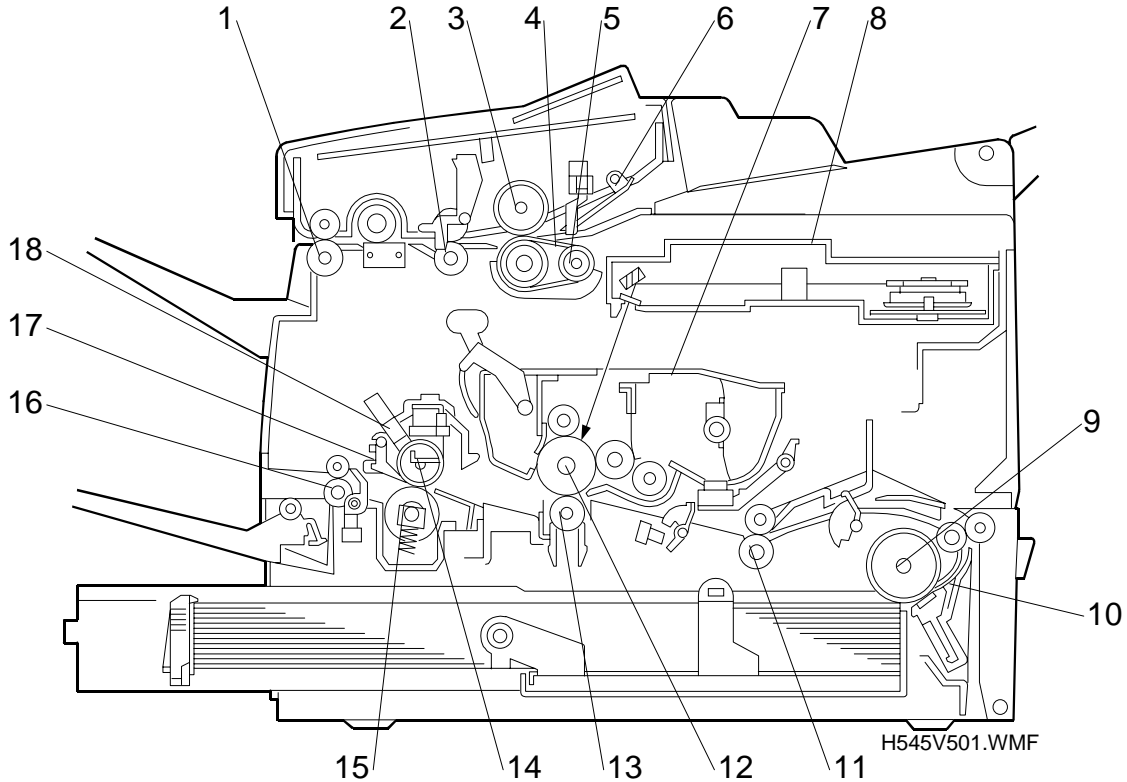

No	Name	Description
1	R2 Roller	Feeds the document through the scanner.
2	R1 Roller	Feeds the document through the scanner.
3	Separation Roller	Allows one page into the scanner.
4	Document Feed Belt	Feeds the document into the scanner.
5	Pick-up Roller	Picks up document pages from the document table one at a time.
6	Pressure Plate	Applies pressure against the pick-up roller.
7	All-in-One Cartridge	Consists of the toner cartridge, cleaning unit, used toner tank, charge brush roller, application roller, development roller and OPC drum.
8	Laser Unit	Consists of the LDDR (Laser Diode Driver), focusing lens, hexagonal mirror motor, and other laser optic components.
9	Paper Feed Roller	Picks up the top sheet of paper from the stack in the cassette, and feeds it into the printer.
10	Separation Pad	Allows one sheet of paper into the printer.
11	Registration Roller	Carries out the registration process.
12	OPC Drum	The latent image is written to this organic photoconductor drum.

No	Name	Description
13	Transfer Roller	Applies a charge to the paper to pull the toner off the drum and onto the copy paper.
14	Hot Roller	Heat from this roller fuses the toner to the copy paper.
15	Fusing Pressure Roller	Applies pressure to the paper during the fusing process.
16	Paper Feed-out Rollers	Feed the paper out of the printer.
17	Hot Roller Strippers	Take the paper off the hot roller after fusing.
18	Cleaning Pad	Cleans up and spreads silicone oil on the surface of the hot roller.

Overall Information

1.3.2 ELECTRICAL COMPONENTS

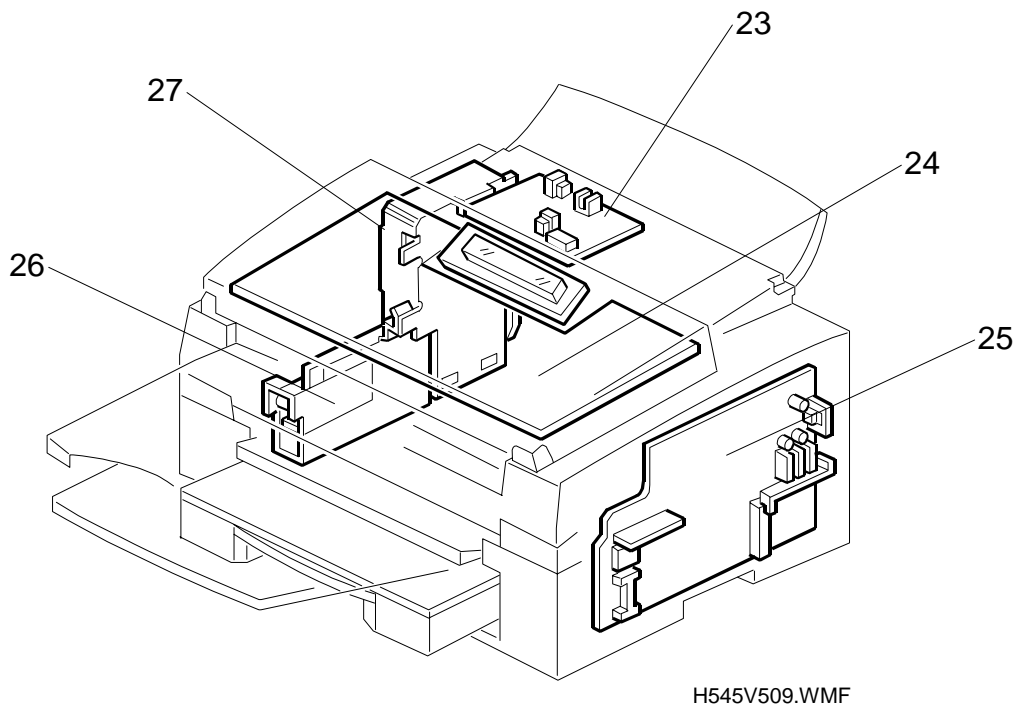
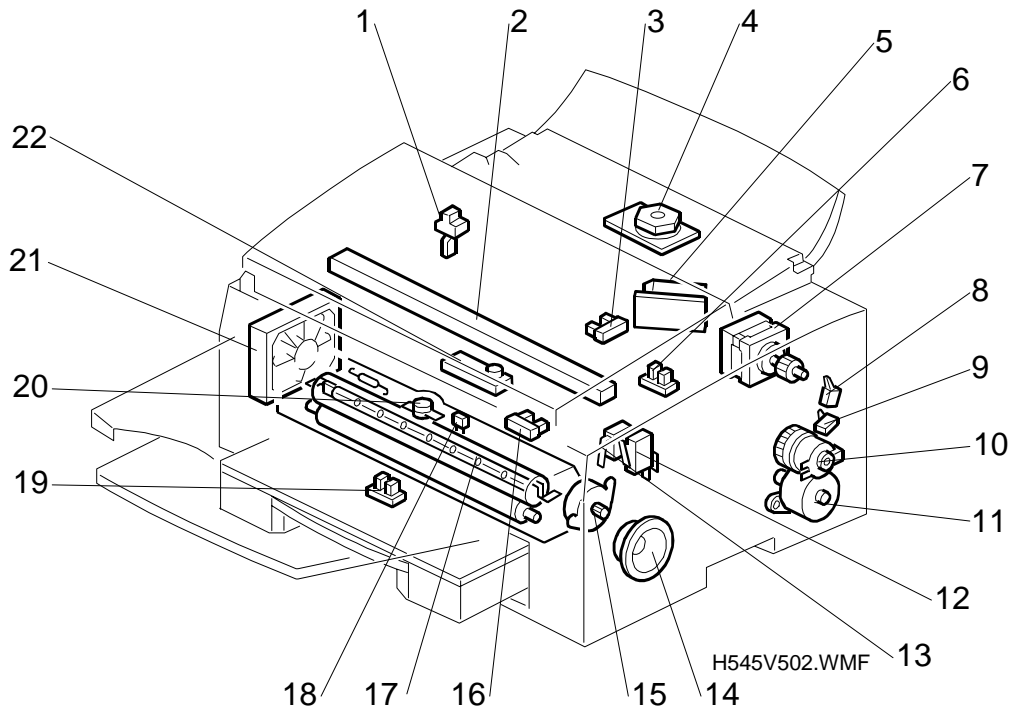

1. PCBs

No	Name	Description
2	CIS (Contact Image Sensor)	This sensor reads and converts the light reflected from the document into an analog video signal.
5	LDDR (Laser Diode Driver)	This board drives the laser diode.
23	NCU (Network Control Unit)	This board contains relays and switches for interfacing the machine with the network and the handset.
24	OPU (Operation Panel Unit)	This board controls the operation panel.
25	FCU (Facsimile Control Unit)	This board controls the machine. It contains the main CPU, flash ROM, system RAM, etc.
26	Power Pack	Supplies high voltage to the charge brush roller, transfer roller and development rollers.
27	PSU (Power Supply Unit)	This board supplies power to the machine, and switches the fusing lamp on/off.

2. Motors

No	Name	Description
4	Polygon Mirror Motor	This high-speed dc motor drives the hexagonal mirror in the laser printer optics.
7	Main Motor	This stepper motor drives the All-in-One cartridge and the fusing unit.
11	Paper Feed Motor	This stepper motor drives the registration roller and the paper feed mechanisms in the cassettes.
15	Scanner Motor	This stepper motor drives the scanner.
21	Cooling Fan Motor	Cools the interior of the machine.

3. Sensors

No	Name	Description
1	Document Sensor	Detects the presence of a document in the feeder.
3	Paper End Sensor	Detects when the paper in the cassette has run out.
6	Paper Edge Sensor	Detects when the paper has passed the paper feed components.
8	Rear Upper Cover Switch	Detects whether the rear upper cover is open or closed.
9	Rear Lower Cover Switch	Detects whether the rear lower cover is open or closed.
16	Registration Sensor	Detects when paper reaches the registration roller.
19	Fusing Exit Sensor	Detects when the paper feeds out of the printer.
22	Toner End Sensor	Detects when the toner has run out.

4. Interlock Switches

No	Name	Description
12 13	Interlock Switches	If the fusing unit cover and/or top cover are open, these switches interrupt the +5VLD power supply for the laser diode and the +24VD power supply for the power pack, motors, and other components.

Overall
Information**5. Others**

No	Name	Description
10	Paper Feed Clutch	Transfers drive from the paper feed motor to the paper feed roller.
14	Monitor Speaker	Allows the user to hear the telephone line condition.
17	Fusing Lamp	The heat from this lamp fuses the toner to the paper.
18	Thermistor	Monitors the temperature on the hot roller surface.
20	Thermostat	Interrupts the ac power supply for the fusing lamp if the thermostat temperature exceeds 400°C.

6. Optional Paper Feed Unit

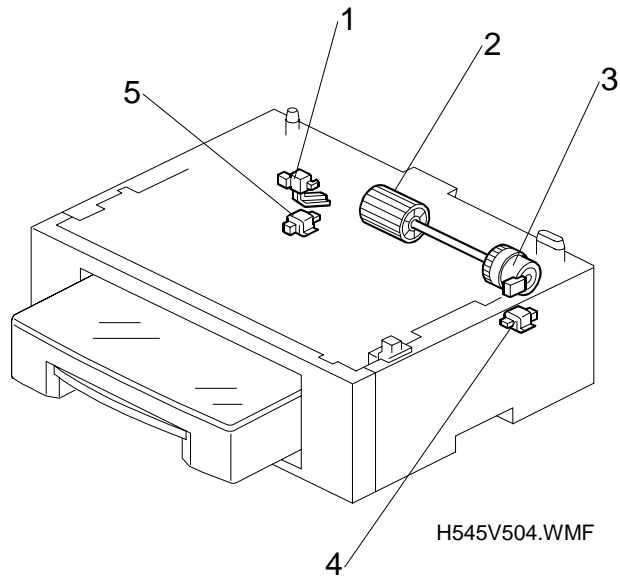

No	Name	Description
1	Paper End Sensor (Paper Feed Unit)	This detects when the paper in the cassette has run out.
2	Paper Feed Roller (Paper Feed Unit)	Picks up the top sheet of paper from the stack in the cassette, and feeds it into the printer.
3	Paper Feed Clutch (Paper Feed Unit)	Transfers drive from the paper feed motor in the mainframe to the paper feed roller in the cassette.
4	Cassette Switch (Paper Feed Unit)	This detects whether the cassette is installed or not.
5	Rear Cover Switch (Paper Feed Unit)	This detects whether the rear cover is open or close.

1.4 OVERALL MACHINE CONTROL

Overall Information

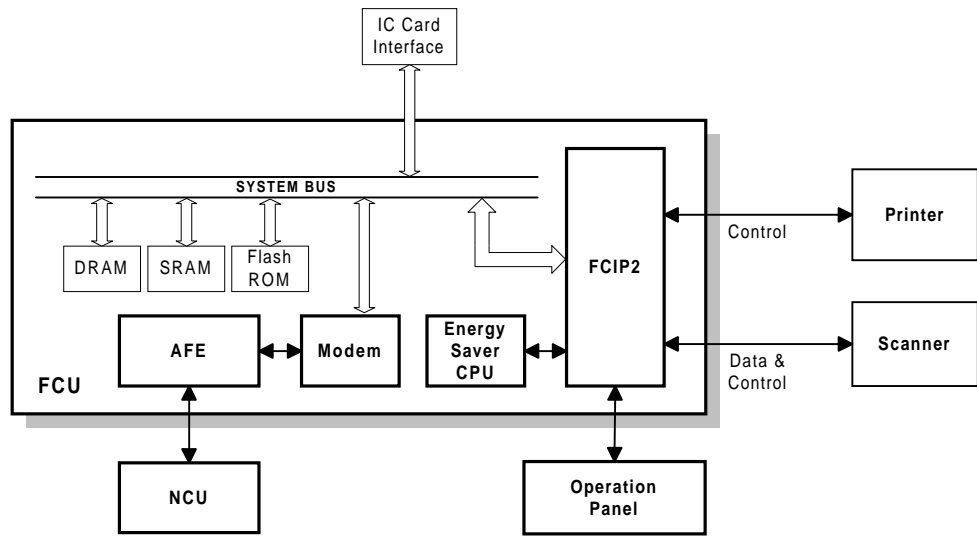

H545V530.WMF

The FCU (Facsimile Control Unit) contains most of the logical components for overall system control.

There are two CPUs in the machine: the main CPU (FCIP2) and the energy saver CPU. Both of these are on the FCU. In energy saver mode, the main CPU switches off and the energy saver CPU takes over.

1.5 VIDEO DATA PATH

1.5.1 TRANSMISSION

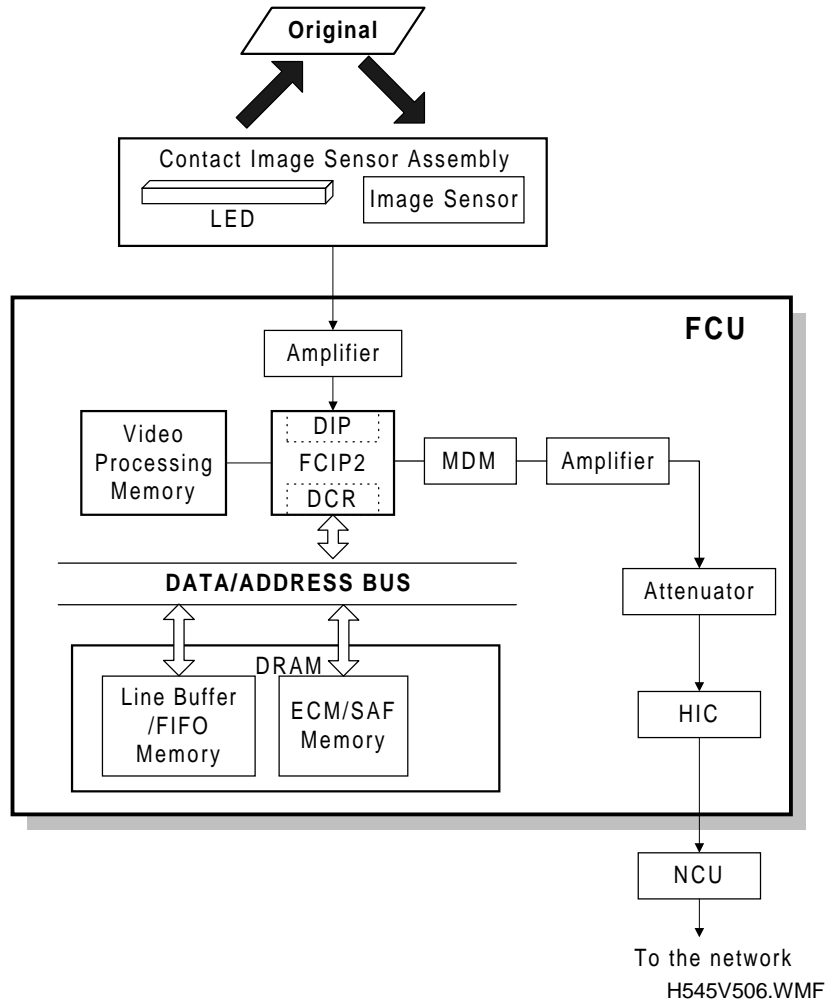

Immediate Transmission:

Scanned data from the contact image sensor passes to the DIP block in the FCIP2. After analog/digital video processing, the DCR block compresses the data for transmission. The compressed data then passes either to the FIFO memory or to the ECM memory before entering the telephone line through the modem.

Memory Transmission:

First, the scanned data is stored in the SAF memory after compression in the DCR block. At the time of transmission, the DCR block decompresses the data from the SAF memory, then compresses it again after handshaking with the other terminal is complete. The compressed data then passes either to the FIFO memory or to the ECM memory, before entering the telephone line through the modem.

1.5.2 RECEPTION

Overall Information

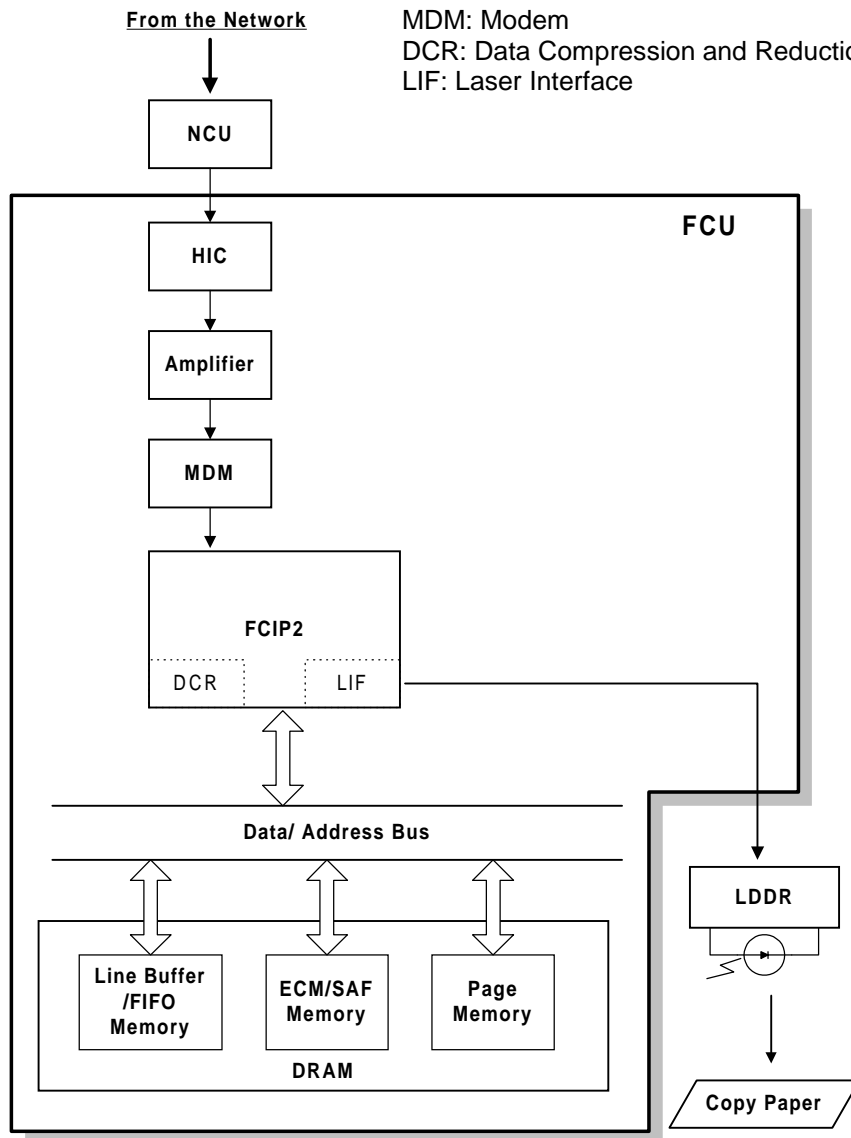

H545V507.WMF

Data from the line passes to the modem through the NCU and hybrid integrated circuit (HIC). After the modem demodulates the data, it passes through either the FIFO or the ECM memory to the DCR block, which decompresses it into raster image data. At the same time, the compressed data passes to the SAF memory as a backup in case of mechanical problems during printing (this is known as substitute reception).

The raster image data then passes to the page memory for printing. After a page of data has been stored in the page memory, the data is sent to the LDDR through the LIF block.

1.5.3 COPYING

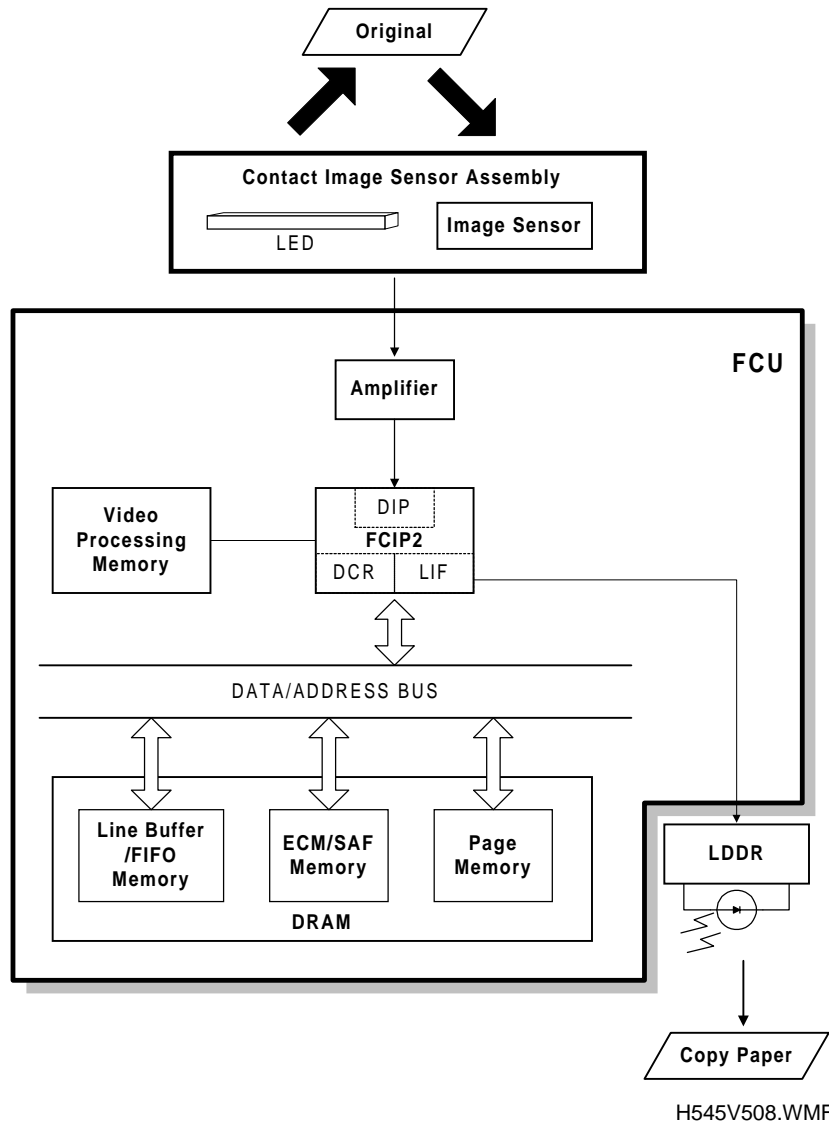

Single copy

The scanned data passes to the page memory after video processing in the DIP block. After a page of data has been stored in the page memory, the data is sent to the LDDR through the LIF block.

Multi-page copy

The scanned data passes to the SAF memory after video processing (DIP) and compression (DCR). After a page of data has been stored in the SAF memory, the data passes to the DCR block again for decompression, and then it passes to the page memory for printing.

1.6 POWER DISTRIBUTION

1.6.1 DISTRIBUTION DIAGRAM

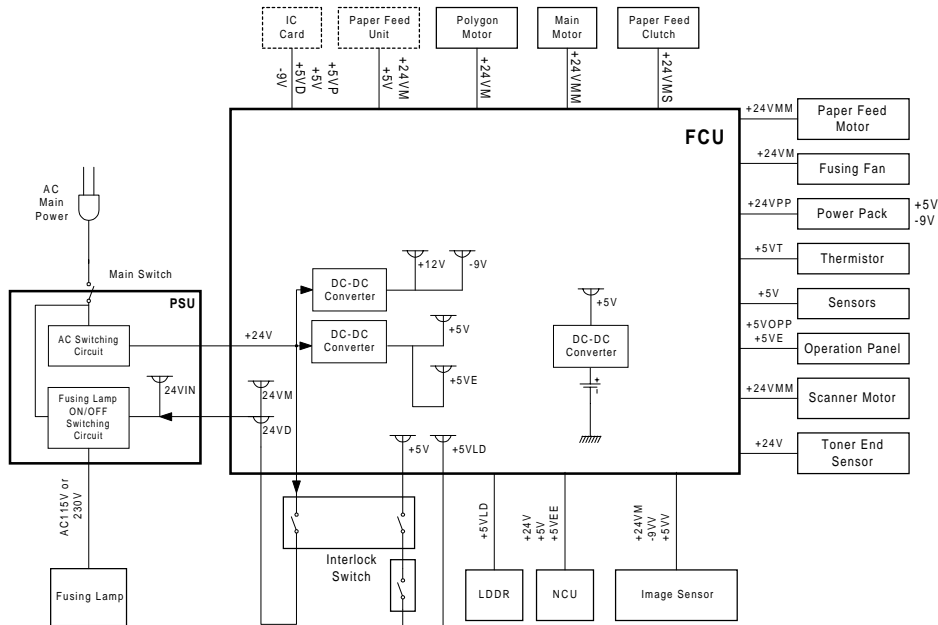

H545V531.WMF

The PSU supplies +24V dc power to the FCU. The FCU converts the +24V into the following supplies:

+5V	Normally on when the main switch is.
+5VE	Detects an activation signal from the NCU, document feeder, or operation panel when the machine is in energy saving mode.
+5VT	For the thermistor.
+5VLD	Supplies the laser diode. It is interrupted if the fusing unit cover interlock switch opens.
+5VV	This is a more stable power supply than +5V. It is used for the contact image sensor.
+5VD	Supplies back up power for the DRAM and the optional IC card on the FCU. It can back up stored data for one hour after the power is switched off. A rechargeable battery on the FCU generates +5VD.
+5VBAT	Supplies back up power to the system RAM on the FCU to back up the programmed data. A lithium battery generates +5VBAT.
+24V	Normally on when the main switch is.
+24VD	This is interrupted if the fusing unit cover interlock switch opens.
+24VIN	Supplies +24V to the fusing unit on/off switching circuit. It is interrupted if the fusing unit cover interlock switch opens.
+24VMM	For the scanner, paper feed, and main motors.
+24VPP	For the power pack.
-9V	For the image sensor.
+5VP	For the optional IC card.

1.6.2 MEMORY BACK-UP CIRCUIT

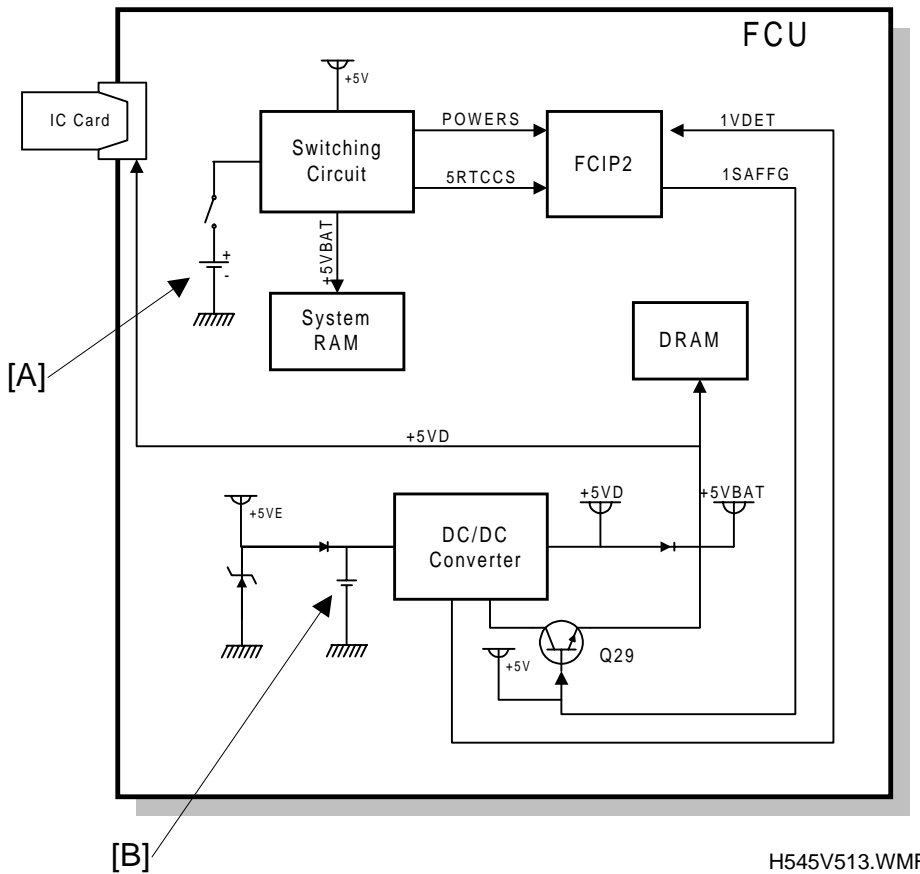

The +5VBAT supply from the lithium battery [A] backs up the system RAM, which contains system parameters, programmed telephone numbers, and the real time clock in the main CPU. The 5RTCCS signal tells the main CPU whether the back-up power (+5VBAT) is coming from the battery or from the +5V power supply.

A rechargeable lithium battery [B] and the DC/DC converter on the FCU back up the DRAM (SAF memory) for one hour, if there is data in the SAF memory and the power is switched off. While the main power is on, the +5VE supply recharges the battery. The battery recharges in 5 or 6 days.

The battery [B] generates about 3 volts (max. 3.2 volts). The DC/DC converter raises this voltage to 5 volts so it can be used as the +5VBD supply for the SAF backup. The CPU monitors the voltage of the +5VBD supply with the 1VDET signal. When the battery has run down, and the voltage is lower than 4.4 volts, the CPU stops the DC/DC converter by dropping 1SAFFG to low and the machine stops backing up the memory.

NOTE: There is no battery switch for the battery [B].

2. DETAILED SECTION DESCRIPTIONS

2.1 SCANNER

2.1.1 MECHANISMS

1. Document Detection

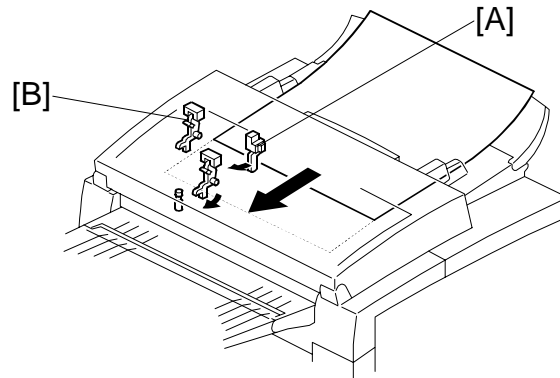

H545D002.WMF

The document sensor [A] detects a document when it is placed in the ADF. The document width sensor [B] detects if the document is A4 or B4 width.

2. Pick-up and Separation and Drive Mechanism

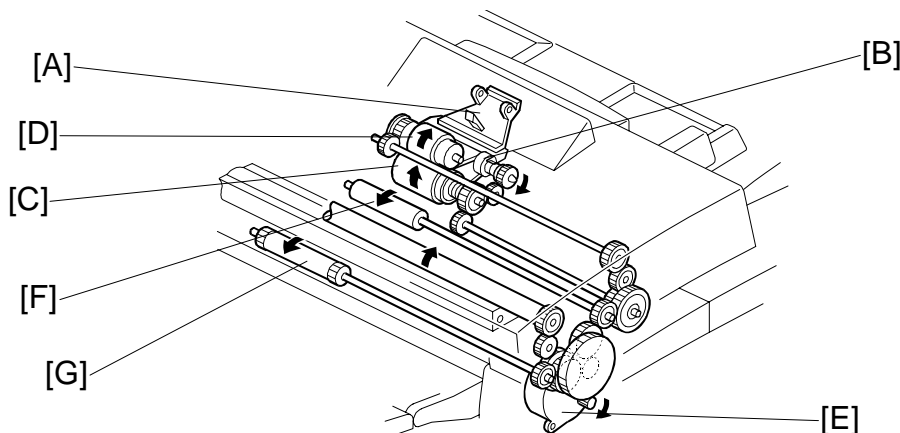

H545D502.WMF

The pressure plate [A] aligns the leading edges of the pages of the document. When the machine starts feeding the document, the mechanical clutch in the ADF roller unit lifts up the pick-up rollers [B] to feed the bottom sheet of the document. Then, the feed belt [C] feeds the sheet into the scanner. The separation roller [D] prevents the feed belt from feeding more than one sheet at a time.

The scanner motor [E] drives the pick-up rollers [B], feed belt [C], R1 roller [F], and R2 roller [G].

Cross Reference

ADF mechanical clutch mechanism: Group 3 Facsimile Manual, page 2-2-8.

Maximum document length: Scanner Switch 00, bits 2 and 3.

4. Image Scanning

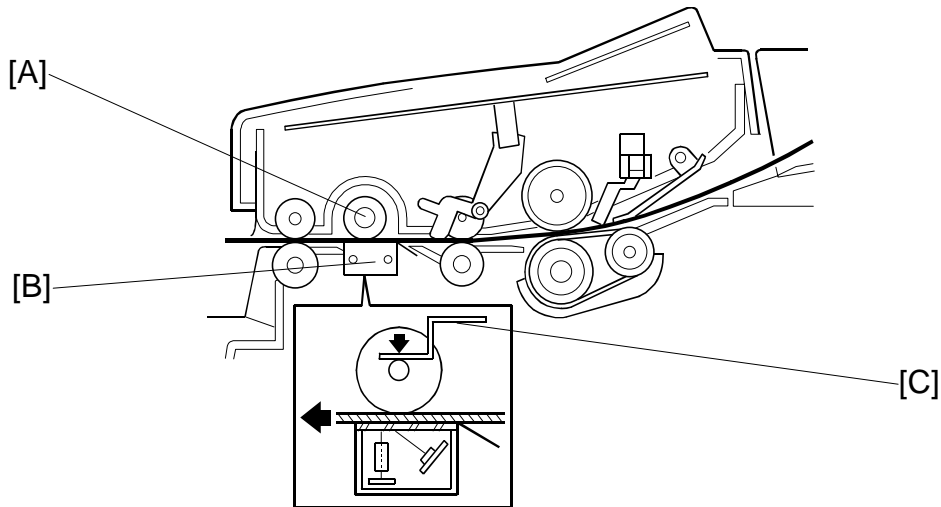

H545D503.WMF

The image sensor [B] consists of a row of photosensitive elements (B4 width x 8 dots/mm). The document reflects light from the LED array and the rod lens array focuses it onto the image sensor. Because of the short optical path inside the CIS, the focal depth is much shorter than for a CCD type scanner. Consequently, the spring plates [C] push the white roller [A] so that the document surface always touches the exposure glass at the scan line.

The image sensor assembly is factory adjusted, so it does not require adjustment or replacement in the field.

The image sensor scans the original one line at a time, and outputs an analog signal for each line. The voltage from each element depends on the intensity of the light reflected from the original onto the element; the light intensity depends on the darkness of the document area it was reflected from.

The white roller [A] must be kept clean, because the machine scans it every page to calibrate the white level (auto shading).

2.1.2 JAM CONDITIONS

The main CPU detects a document jam if one of the following conditions occurs.

Jam Condition	Description	Error Code
Non-feed	The feed mechanism attempts to feed the paper once every second for a maximum of 6 seconds. If the scan line sensor does not detect the document within 6 seconds, the monitor displays an error message.	1-00
Incorrect sensor conditions	The scan line sensor turns on while the document sensor is off.	
Maximum document length exceeded	The scan line sensor does not turn off after the maximum document length has fed through it. This occurs after 11 seconds at standard resolution for memory TX; 23 seconds at standard resolution for immediate TX or detail resolution; or 46 seconds at fine resolution (all these times are for a 1.2-m long document).	1-01
Cover open	While the ADF is working, the ADF cover is opened.	No error code
Error during feed-out	The scanner motor reverses when the final page of the document feeds out of the scanner and/or when removing a jammed document. This error occurs when placing a document into the feeder while the motor is rotating.	No error code

Detailed Descriptions

2.2 PRINTING

2.2.1 PRINTING PROCESS - OVERVIEW

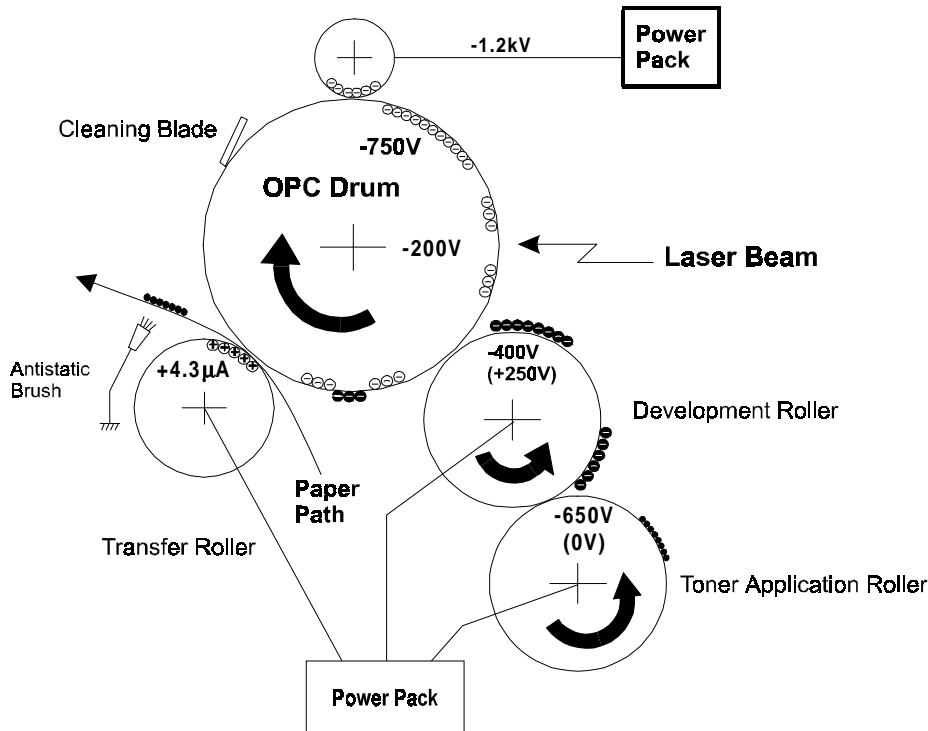

H545D521.WMF

This machine uses a “write-to-black” system, with negative toner.

- The charge-brush roller gives the drum surface an approximate negative charge of $-750 V$.
- The exposed area on the drum drops to about $-200 V$.
- The development roller carries toner to the latent image on the drum surface.
The bias voltages during printing:
Toner application roller : $-650 V$
Development roller: $-400 V$
- The transfer roller pulls the toner from the drum onto the paper.
A constant current of $+4.3 \mu A$ is applied. The anti-static brush helps to separate the paper from the drum.
- The cleaning blade removes any toner remaining on the drum after the image transfers to the paper.
- This machine does not use quenching lamp.

2.2.2 OPC DRUM

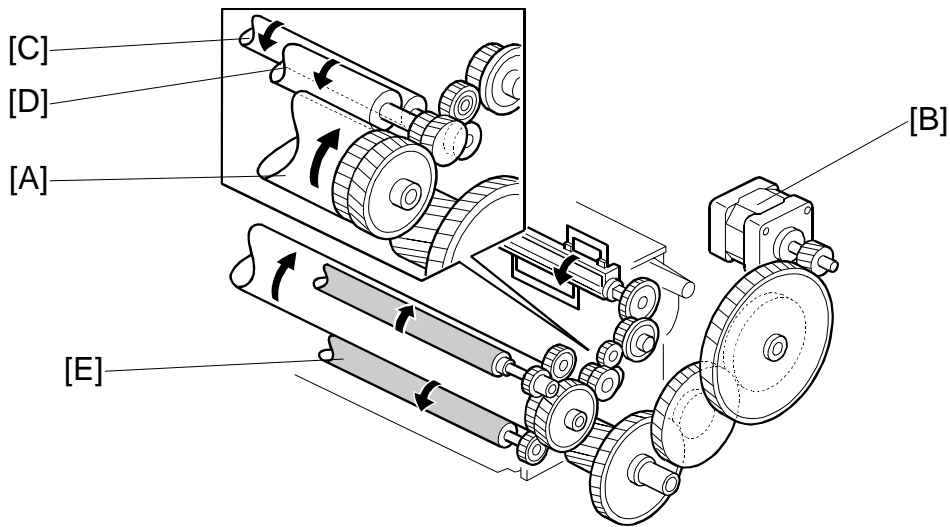

H545D504.WMF

The cartridge contains an organic photo-conductor drum [A]. The diameter of the drum is 24 mm. The main motor [B] drives it through a gear train. The same gear train also drives the toner application roller [C], development roller [D], and transfer roller [E].

The drum, development roller, fresh and used toner tanks, and cleaning mechanism are all included in the cartridge, which is known as the “All-in-One” cartridge.

2.2.3 CHARGE

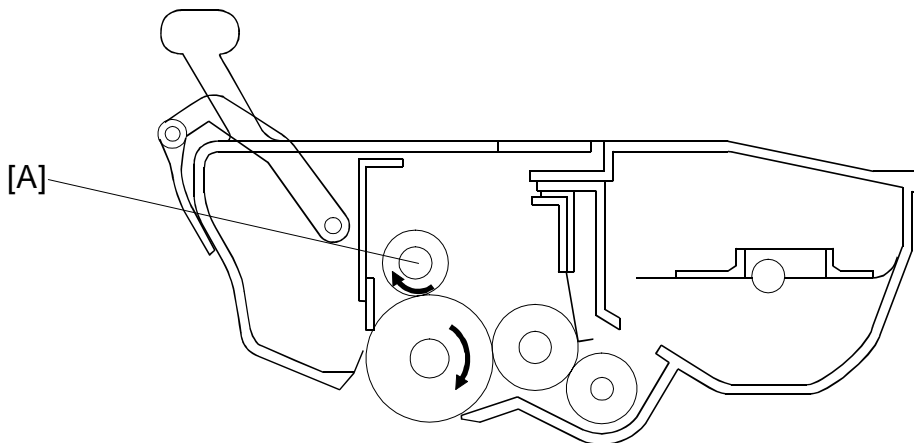

H545D517.WMF

The cartridge contains a charge brush roller [A]. The diameter of the roller is 12 mm. The charge brush roller does not generate ozone. The power pack applies a constant voltage of about -1.2 kV. The charge brush roller gives the drum surface a negative charge (-750 V).

Detailed Descriptions

2.2.4 LASER EXPOSURE

Overview

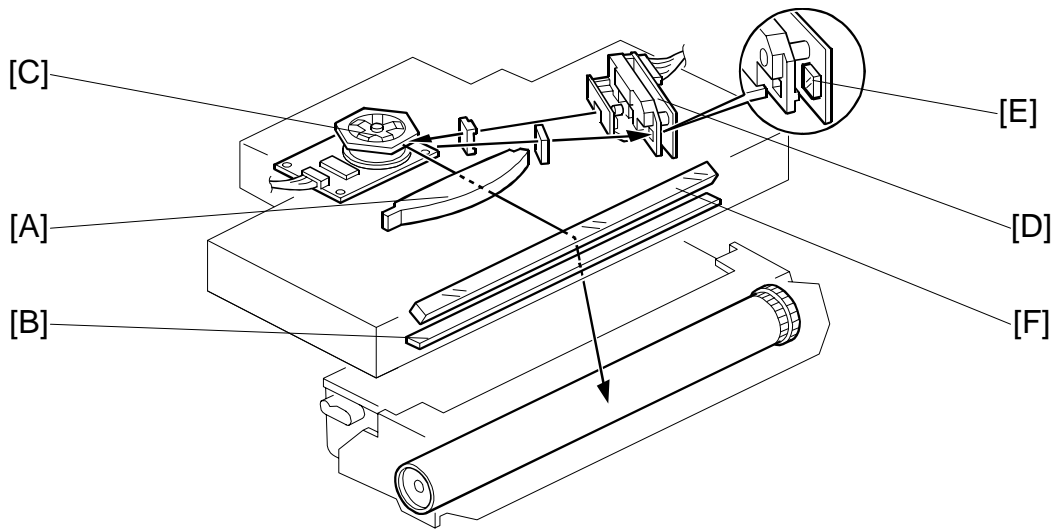

H545D505.WMF

- The focusing lens [A] is a double toroidal lens that has a barrel toroidal surface on both sides.
- The shield glass [B] prevents toner and dust from entering the laser optics area.
- The speed of the hexagonal mirror motor [C] is 5793.88 rpm (16 x 15.4 dots/mm).
- The strength of the beam emitted from the LD unit [D] is 0.2 mW with a wavelength of 780 nm. The photo transistor [E] inside the LD unit synchronizes the laser main scan.
- The mirror [F] reflects the laser beam onto the drum.

The charge on the exposed areas of the drum drops to about -200V while non-exposed areas remain at around -750V.

As a mechanical safety feature, a shutter slides to block the laser beam path whenever the upper unit is opened.

Cross Reference

Group 3 Facsimile Manual: section 4-3-3

Block Diagram

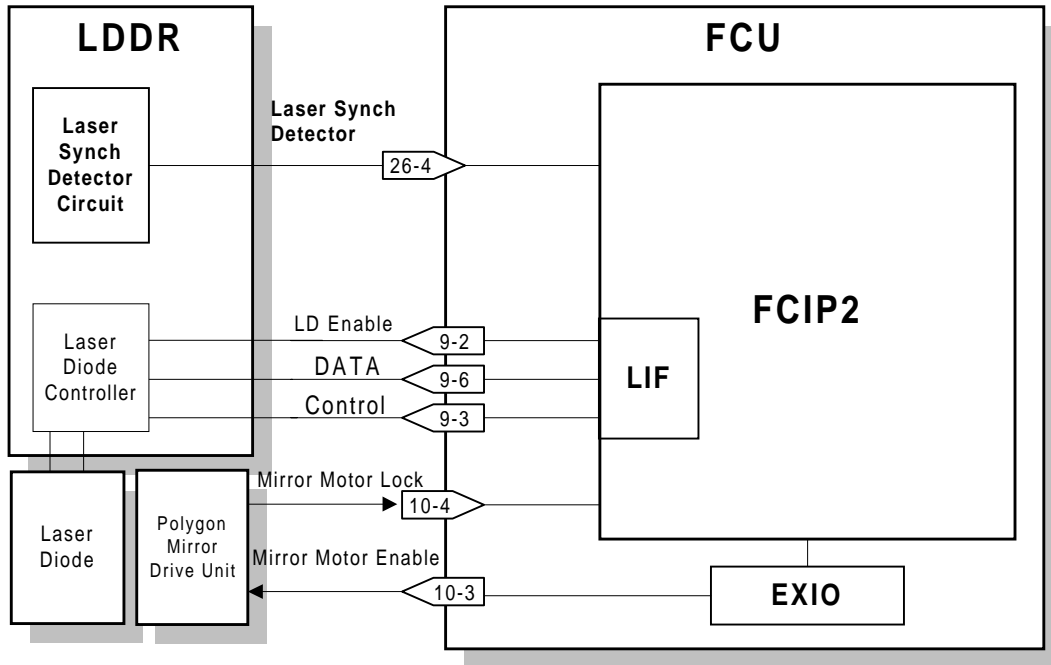

Detailed Descriptions

H545D506.WMF

The LIF (Laser Interface) circuit inside the FCIP2 monitors and controls the laser diode timing (FCU CN9-3), and transfers data for printing to the laser diode (FCU CN9-6).

Cross Reference
 Group 3 Facsimile Manual: page 4-3-13

Error Conditions

LD Failure:

The machine detects LD failure when it does not detect the laser synchronization signal within 10 ms of the LD ready signal. When this occurs, the machine warns the customer with the Call Service indicator (error code 9-20).

Mirror Motor Failure:

The machine detects a mirror motor error when the FCU CN10-4 signal does not go low within 10 seconds of the hexagonal mirror motor turning on. The machine also detects a mirror motor error when the FCU CN10-4 signal goes back to high for 3 seconds or more during mirror motor operation. When either of these errors occurs, the machine warns the customer with the Call Service indicator (error code 9-23).

2.2.5 TONER SUPPLY

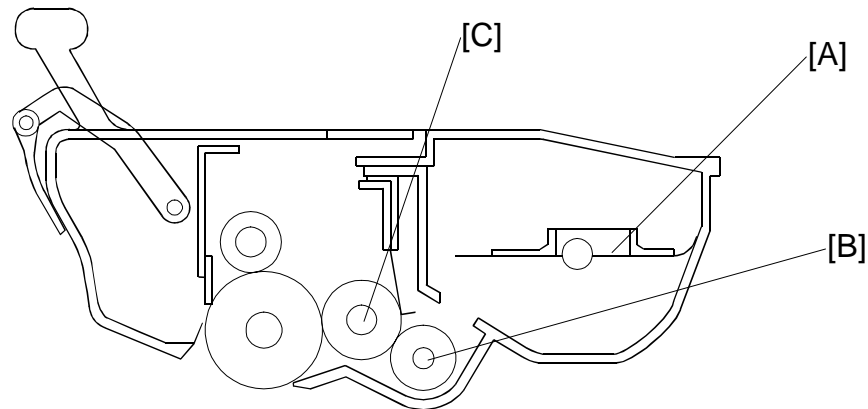

H545D519.WMF

This machine uses mono-component toner, composed of resin and ferrite. The toner mixing bar [A] stirs and carries toner to the toner application roller [B]. The toner application roller supplies toner to the development roller [C].

The main motor drives the toner supply mechanism through a gear train.

Since the toner tank and the development unit is composed in one unit, initial toner supply mode is not required for this machine.

Cartridge Detection

This machine does not have toner cassette detection mechanism. It only detects output from the toner end sensor.

At the following times, the toner end sensor detects whether a cartridge is installed in the machine.

- At power-up.
- When the machine comes back to normal mode from the level 2 Energy Saver Mode.
- After opening and then closing the cover.

Toner End Detection

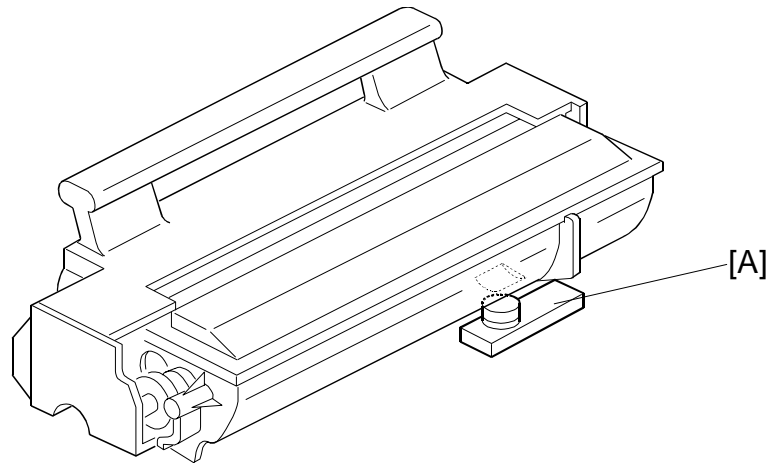

H545D516.WMF

The toner end sensor [A] below the toner tank detects toner near-end.

While the main motor rotates, the machine detects toner end by the voltage output from the toner end sensor. The voltage from the sensor is close to 5V when the toner tank is full and decreases when the toner is almost used up.

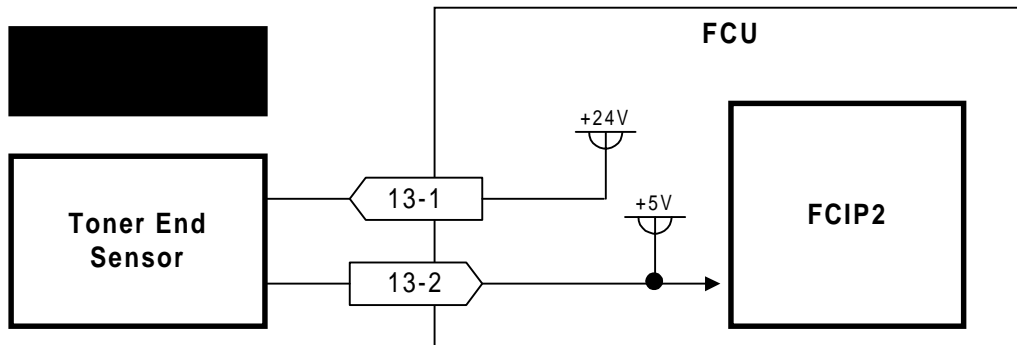

H545D507.WMF

Toner near-end condition: When the cpu detects a low output (below a certain threshold) from the toner end sensor for a few seconds, the cpu starts to blink the Add Toner indicator (LED). This is the toner near-end condition.

Toner end condition: After toner near-end is detected, the machine can print 100 more sheets, then the cpu disables printing (this is the toner end condition).

The machine clears the toner near-end or toner end condition when the power is switched off and back on or when the cover is opened and closed, if the output from the toner end sensor goes back high again.

NOTE: If the toner end sensor is accidentally disconnected, the machine cannot detect if the cartridge is installed. The machine assumes that there is still toner, even if the toner tank is empty.

Detailed Descriptions

2.2.6 DEVELOPMENT

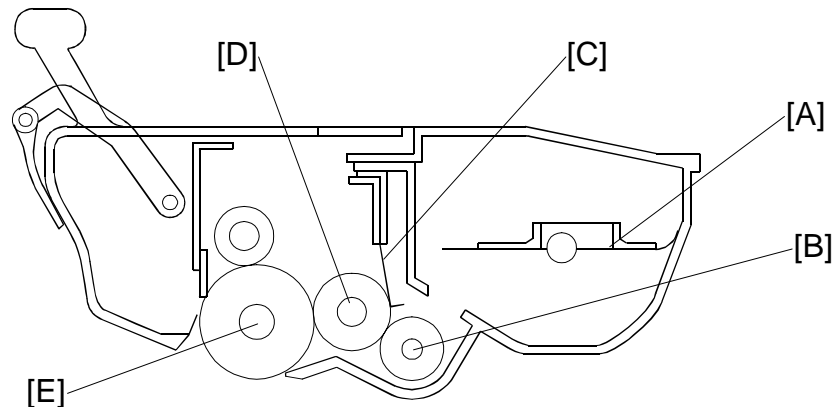

H545D519.WMF

Overview

The toner supply bar [A] stirs and carries toner to the toner application roller [B]. The toner application roller is a sponge-like structure which carries toner to the development roller [D]. As the development roller [D] turns past the toner metering blade [C], only a thin coating of negatively charged toner particles stays adhered. (Refer to section 4-4-2 of the Group 3 Facsimile manual.)

During printing, the power pack applies a bias voltage of -650V to the toner application roller and another bias voltage of -400V to the development roller. The potential difference between these two rollers carries the toner from the toner application roller to the development roller.

The exposed area on the drum [E] is at -200V. The development roller applies toner to the latent image areas as they turn past the drum.

The development roller is made of soft rubber so it does not damage the surface of the drum.

Development Bias

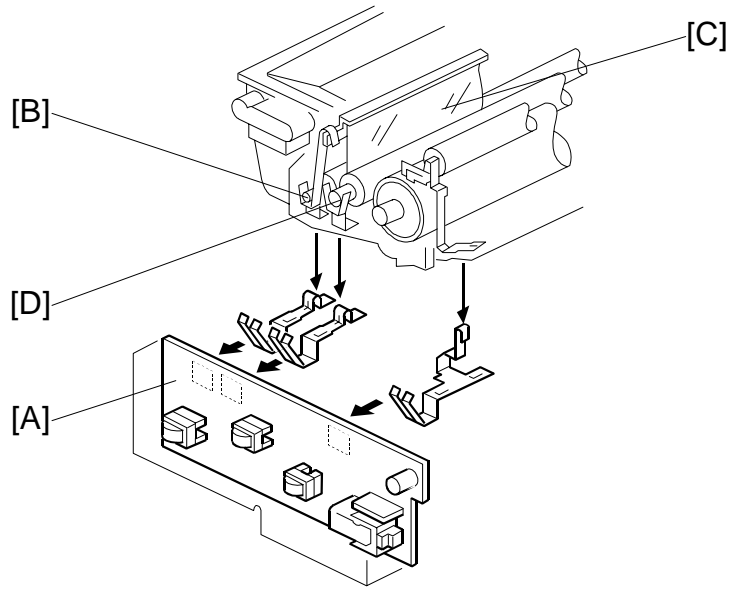

H545D518.WMF

The power pack [A] applies one voltage to the toner application roller [B] and toner metering blade [C], and a different voltage to the development roller [D].

Bias Control (During Printing)

The power pack applies a charge of -650V to the toner application roller, and -400V to the development roller. Toner transfers from the toner application roller to the development roller and on to the laser-exposed areas on the drum as shown below.

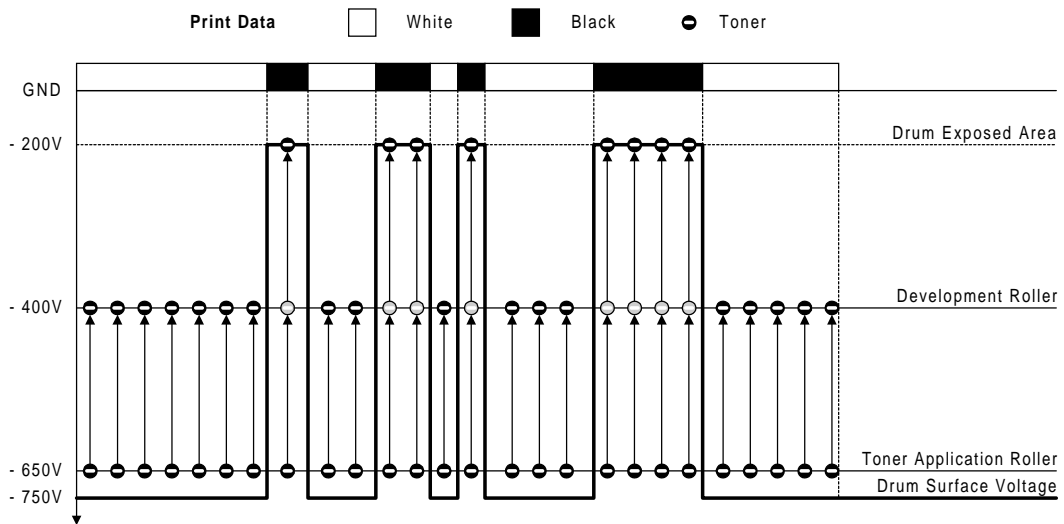

H545D531.WMF

Detailed Descriptions

Bias Control (After Each Page)

At the start and the end of any print process (including the cleaning mode), the power pack applies 0V to the toner application roller, and +250V to the development roller. This is to prevent toner from transferring to the drum.

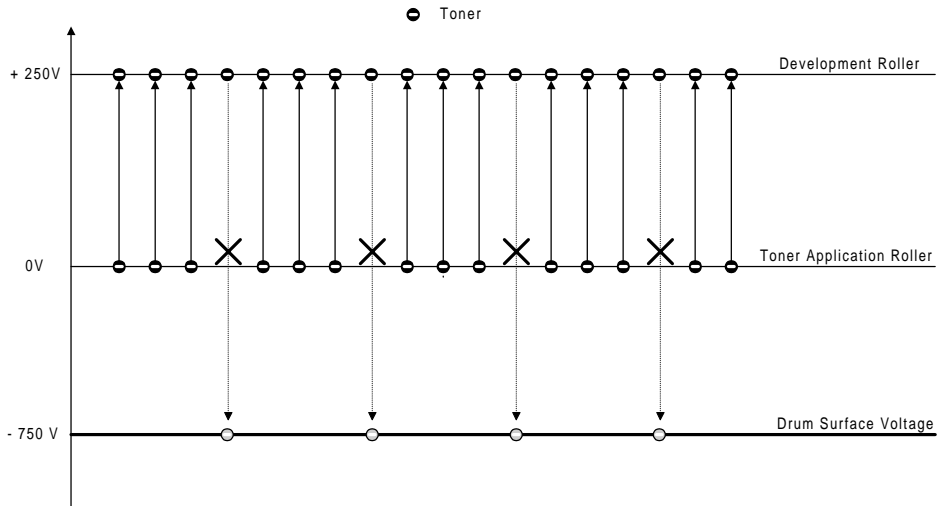

H545D533.WMF

Note that the voltage difference between the toner application and development rollers is kept the same as in printing, at 250 V. This keeps the same amount of toner on the development roller at all times during the print run.

Bias Control Circuit

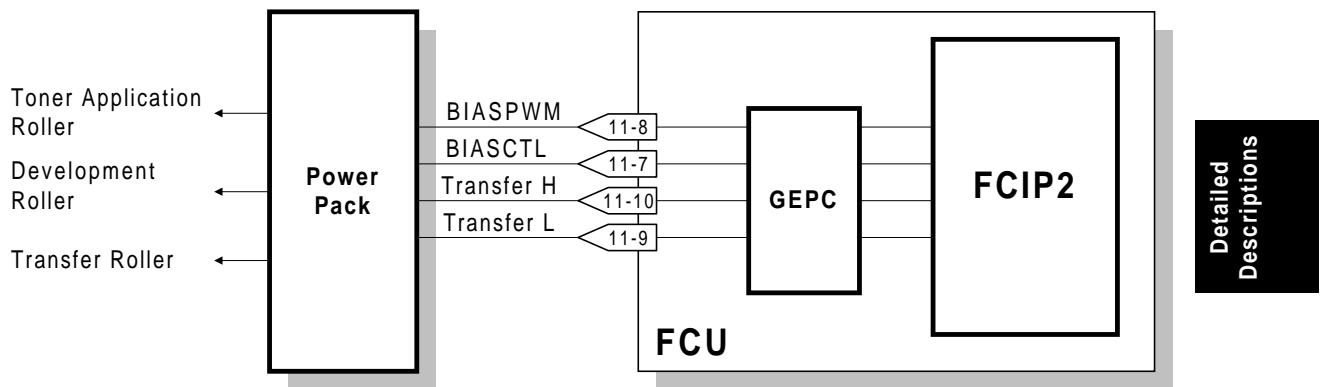

H545D509.WMF

The CPU controls the voltages to the toner application and development rollers through the power pack controller (GEPC), using the BIASCTL and BIASPWM signals as shown in the following table.

In	BIASCTL	Low	High	Low	High
	BIASPWM	On	On	Off	Off
Out	Toner Application Roller	- 650 V	0 V	Off	Off
	Development Roller	- 400 V	+ 250 V	Off	Off

2.2.7 PAPER FEED

Overview

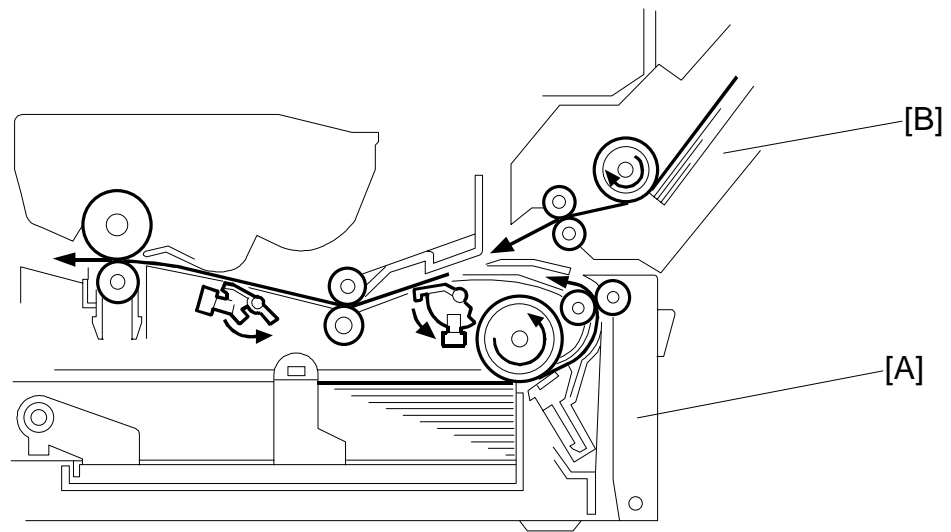

H545D511.WMF

The standard cassette [A] holds 250 sheets.

An optional paper feed unit, which holds up to 500 sheets, is available (only one of these can be installed).

NOTE: An optional multi-purpose feeder [B] is not available in the Taiwan model.

Paper Lift Mechanism Standard Cassette

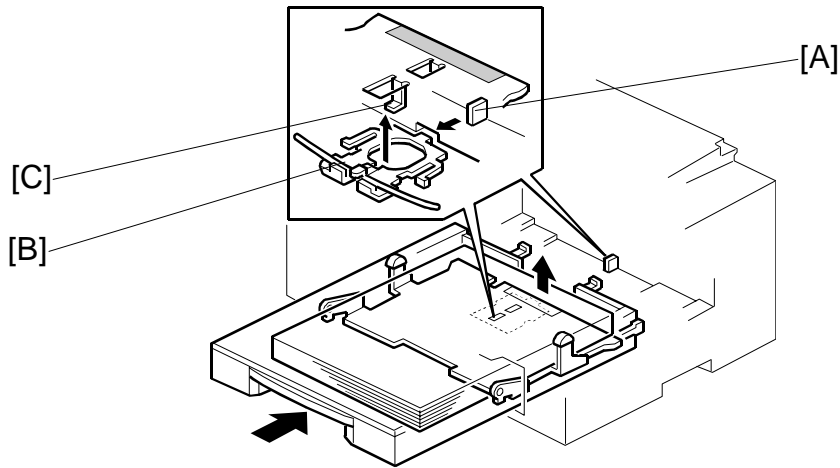

H545D525.WMF

After loading the paper and closing the cassette, the projection [A] pushes the slide lock [B] off the bottom hook [C].

Once the slide lock comes off, the pressure spring lifts the bottom plate.

Optional Paper Feed Unit

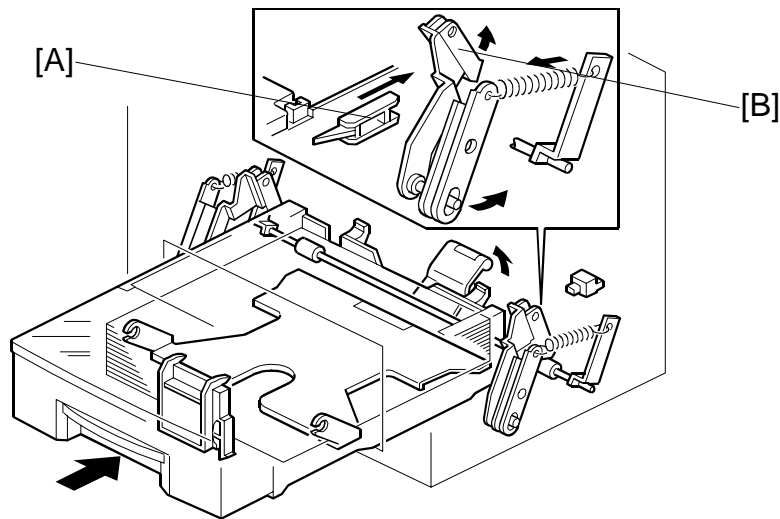

H545D513.WMF

After loading the paper and closing the cassette, the projection [A] pushes the lever [B], then the springs raise the bottom plate.

Detailed
Descriptions

Paper End Detection

Standard Cassette/Optional Paper Feed Unit

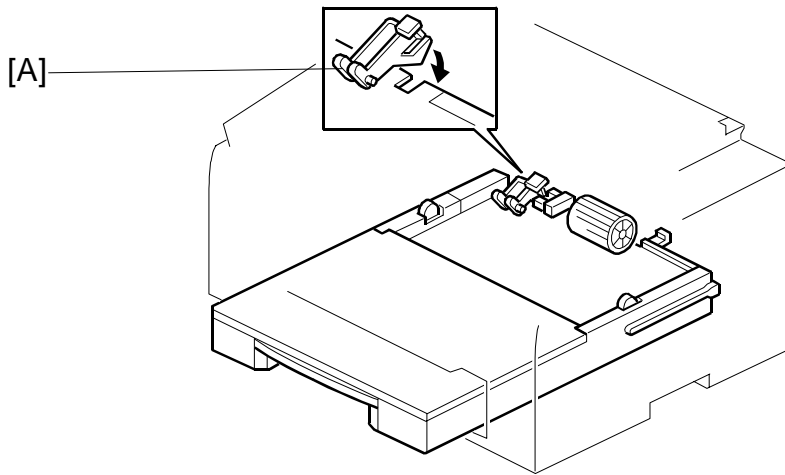

H545D527.WMF

When the cassette runs out of paper, the paper end sensor actuator [A] drops through a slot in the bottom plate.

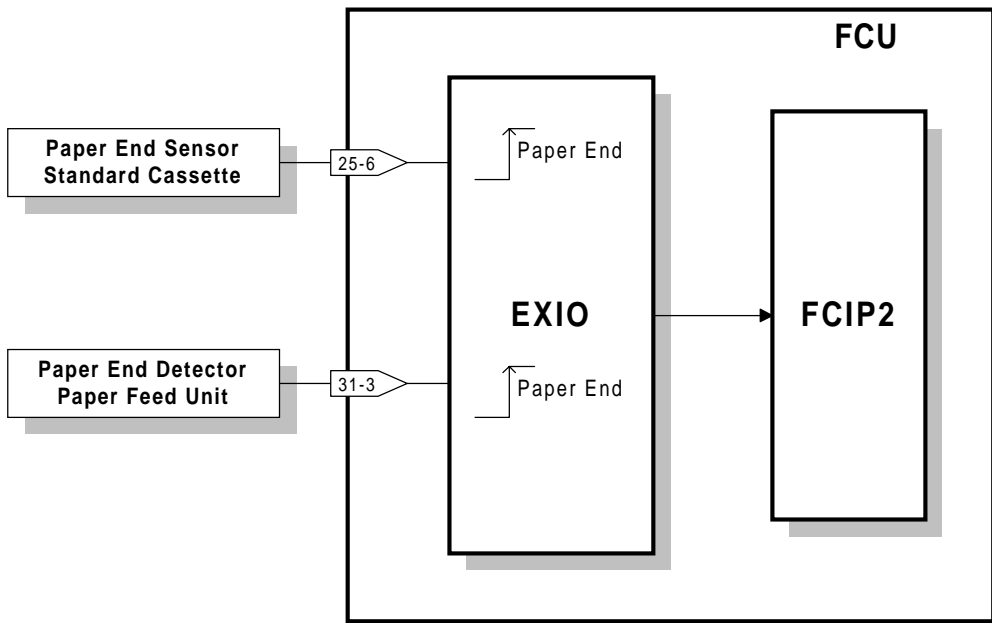

H545D700.WMF

Pick-up and Separation

Standard Cassette and Optional Paper Feed Unit

The pick-up and separation mechanism is a separation pad type. The separation pad and the paper feed roller allow only one sheet to feed.

Cross Reference

Group 3 Facsimile Manual: section 4-5-4

The paper feed motor in the mainframe starts to rotate when the printer is ready for printing.

Detailed
Descriptions

Drive Mechanism

Standard Cassette

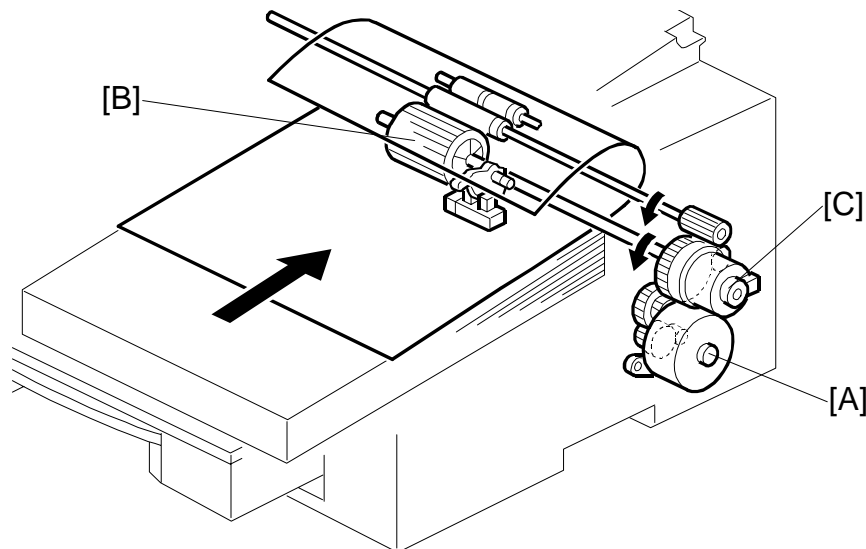

H545D522.WMF

The paper feed motor [A] drives the paper feed mechanism. When using the standard cassette, the paper feed motor turns clockwise, driving the paper feed roller [B], as shown in the diagram.

The clutch [C] only allows the paper feed roller to turn once for each sheet of paper.

Optional Paper Feed Unit

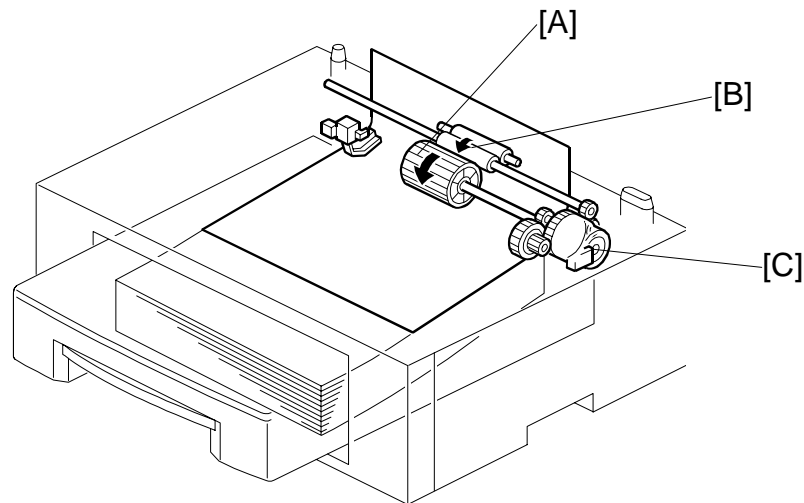

H545D508.WMF

The paper feed motor in the mainframe drives the paper feed mechanism through a gear train. When the optional paper feed unit is used, the paper feed motor turns counter-clockwise, driving the paper feed roller [A] and the transport roller [B], as shown.

The paper feed clutch [C] in the optional paper feed unit ensures that the paper feed roller rotates only once for each sheet of paper.

Paper Feed Priority

If there is an optional paper feed unit installed in the machine, deciding paper feed priority is in accordance with the following rules:

- If both cassettes contain paper of the same size, the machine uses the optional paper feed unit.

2.2.8 REGISTRATION

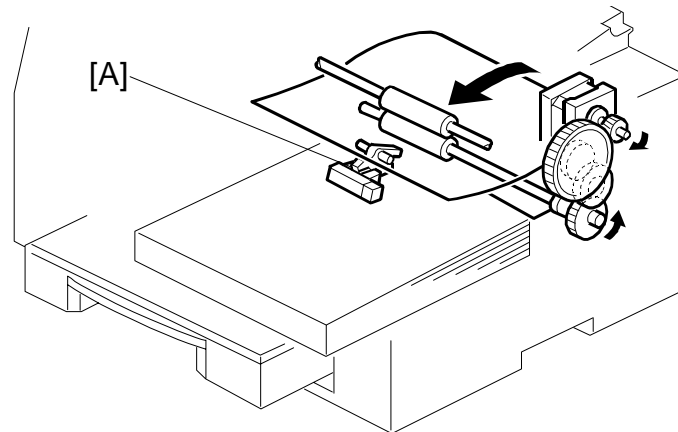

H545D523.WMF

Detailed
Descriptions

When the paper edge sensor [A] turns on, the machine slows the paper feed motor.

Then, a certain time after the paper's leading edge turns on the registration sensor, the machine starts to write the latent image to the drum.

When the paper edge sensor turns off, the machine speeds up the paper feed motor to feed the next page and stops the laser.

Jam Detection

	Condition	Error Code
Standard Cassette	When the paper edge sensor does not turn on within 2.6 seconds of the paper jam timing signal.	9-07
	When the registration sensor is not turned on within 5.5 seconds after the paper edge sensor turns on. When the paper edge sensor does not turn off within 9.47 seconds after the registration sensor turns on.	9-84
Any Paper Feed Station	When the fusing exit sensor does not turn on within 5.0 seconds after the registration sensor turns on	9-08
	When the registration sensor does not turn off within 4.84 seconds after the paper edge sensor turned off. When the fusing exit sensor does not turn off within 5.0 seconds after the registration sensor turns off.	9-09
Optional Paper Feed Unit	When the paper edge sensor does not turn on within 2.6 seconds after the paper feed clutch turns on.	9-50
	When the registration sensor does not turn on within 5.5 seconds after the paper edge sensor turns on. When the paper edge sensor does not turn off within 9.47 seconds after the registration sensor turns on.	9-51

2.2.9 TRANSFER AND SEPARATION

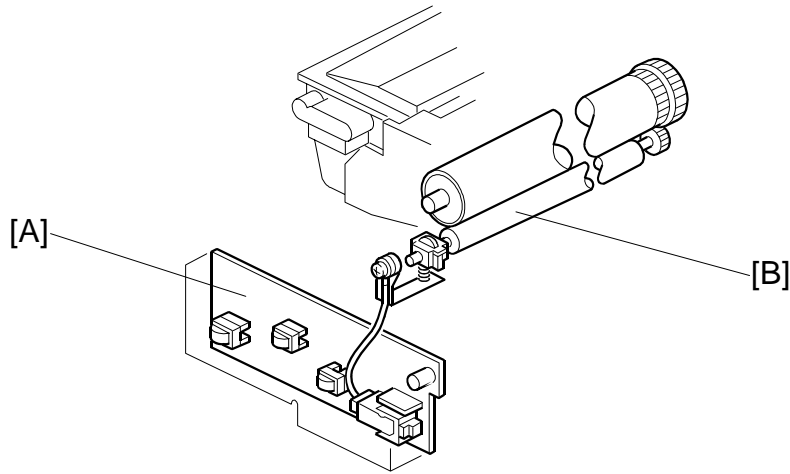

H545D526.WMF

Detailed Descriptions

Instead of using a transfer corona wire, this machine uses a transfer roller, which touches the drum surface.

The power pack [A] applies a constant current of $+4.3 \mu\text{A}$ to the transfer roller [B]. The positively biased transfer roller pulls negatively charged toner off the drum. The curvature of the drum and the anti-static brush help the paper to drop away from the drum.

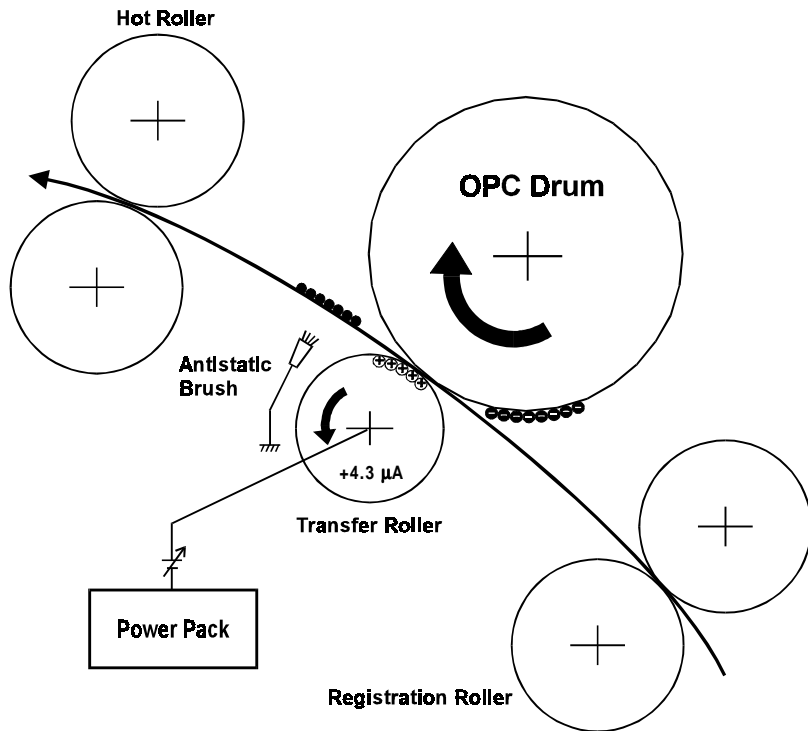

H545D536.WMF

Cleaning Mode

If the paper is smaller than the printed image, or if a paper jam occurs during printing, toner may transfer to the roller surface. To prevent this from occurring, the transfer roller is cleaned before the next printing run.

While the machine is cleaning the transfer roller, the power pack supplies -1200V to the transfer roller, and charges the drum to -750V. The negatively charged toner on the transfer roller transfers back to the drum.

The machine cleans the transfer roller under the following conditions:

- At power on (when the fusing temperature reaches half of the standby temperature).
- When the cover is opened and then closed during the printing process.
- After clearing a printer jam.

The CPU controls the transfer roller voltage through the power pack using the following signals.

In	THTRG	On	Off	On	Off
	TLPWM	Off	On	On	Off
Out	Transfer Roller	+ 4.3 μ A	- 1200 V	-	Off

2.2.10 CLEANING

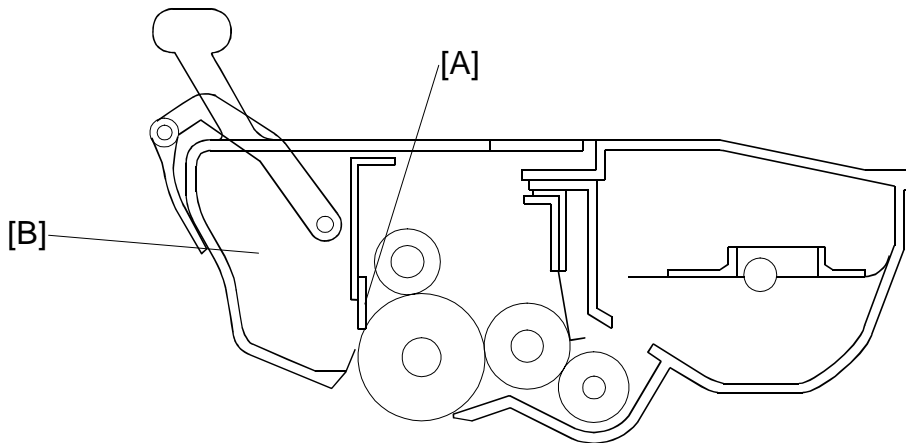

H545D519.WMF

The cartridge contains the cleaning unit and the used toner tank.

The cleaning blade [A] removes any toner remaining on the drum after the image is transferred to the paper, and then brings the toner into the used toner tank [B].

There is no used toner overflow detection mechanism because the used toner tank is large enough for the lifetime of the cartridge.

2.2.11 FUSING

Fusing Lamp Control

During printing, the machine keeps the fusing temperature at 170°C. If the printing operation continues for more than 3 minutes, the machine keeps the fusing temperature at 160°C.

When the Energy Saver Key is pressed or the energy saver timer expires, the machine goes into an energy saver mode. In Level 2 Energy Saver Mode (2-watt Energy Saver Mode), the fusing lamp shuts off. For Energy Saver Mode Level 1, the user can select whether to keep the fusing lamp off or at 80°C.

Detailed Descriptions

Cross Reference

Energy Saver Modes: Section 2-3

Points to Note:

- Standby temperature: Room temperature (2 watt-Energy Saver Mode), 80 °C if users select 'Fusing Lamp On'
- Printing temperature: 170 °C, falling back to 160 °C after 3 minutes
If the initial lamp temperature is over 120 °C before printing, the printing temperature is 160 °C.
- Thermistor maximum: 250 °C (monitored by a comparator)
- Thermostat maximum: 150 °C (the temperature of the hot roller would be about 400 °C)
- Thermofuse maximum: 169 °C (the temperature of the hot roller would be about 400 °C) - The thermofuse is not used in USA models.

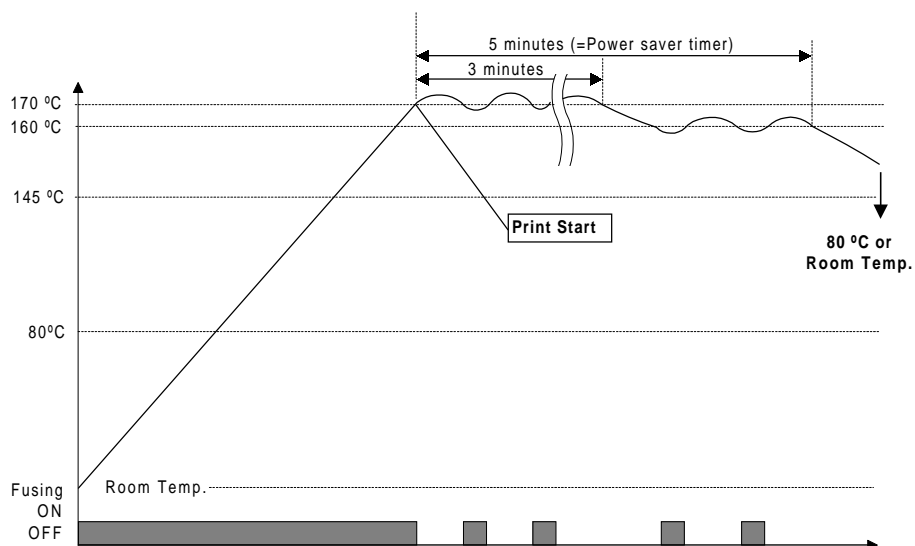

H545D538.WMF

Fusing Control

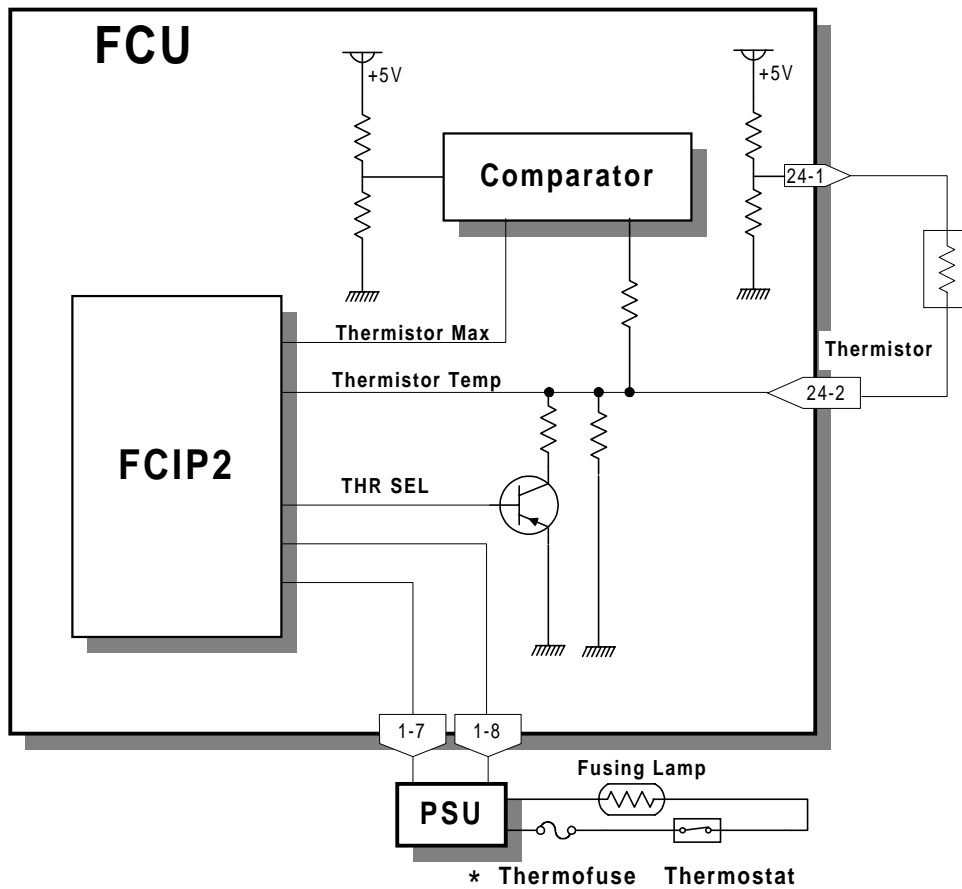

H545D662.WMF

The thermofuse is installed only in the Europe model.

During normal operation, the CPU controls the fusing lamp based on input from the thermistor using the above circuit.

When the machine is turned on, or when it comes back from the Level 2 Energy Saver Mode, it checks whether the thermistor circuit is intact by using the THR SEL signal on the FCU. If the thermistor is connected properly, the machine begins normal operation. If it is not, it generates an Auto Service Call (error code 9-22, sub-code 09).

As a backup safety measure, when the temperature of the hot roller reaches approximately 400 °C, the thermostat and/or thermofuse open.

The machine turns on the cooling fan when the fusing temperature reaches 60°C and shuts it off when the fusing temperature drops below 60°C.

Fusing Unit Drive

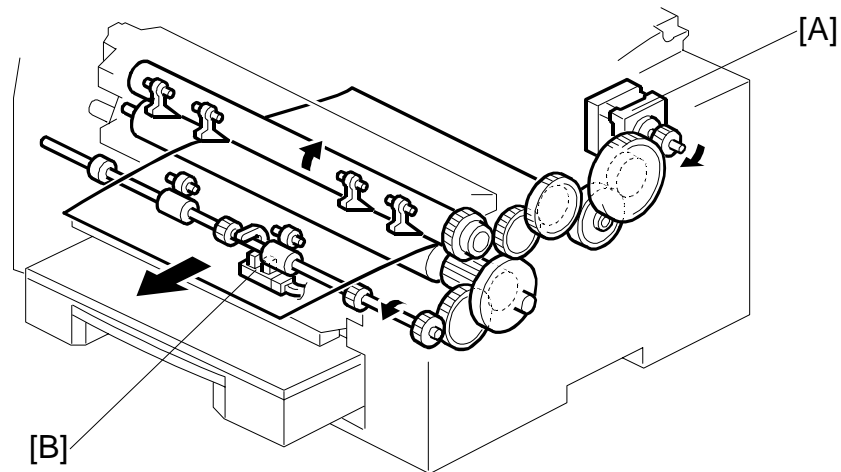

H545D524.WMF

Detailed
Descriptions

The main motor [A] drives the fusing unit through a gear train. The fusing exit sensor [B] detects when the paper is fed out of the unit.

After opening the upper unit, the gear train frees up making it easy to remove jammed paper.

Jam Detection - Paper Feed Out

The machine detects a paper jam when the fusing exit sensor does not turn off within 5.0 seconds after the registration sensor turns off (Error Code 9-09).

This is the same for all cassettes.

Fusing Unit Service Call Conditions

	Conditions	Error Code (9-22)
At power on	If there is a problem with the thermistor. (Also for when the machine returns to Normal Mode from Energy Saver Mode Level 2.)	Sub-code 09
	If the machine detects that both jumper 63 and jumper 64 are shorted. *[The status of the jumpers determines the model type. (USA, Europe/Asia, Japan)]	Sub-code 0B
Standby mode	If the fusing temperature stays below 70 °C for more than 36 seconds after selecting fusing lamp ON in Energy Saver Mode Level 1 or when in Standby Mode.	Sub-code 05
	If the fusing temperature takes more than 60 seconds to reach 145°C from the standby temperature.	Sub-code 02
	Either: If the fusing temperature stays above 110°C for more than 180 seconds after selecting the power saver standby temperature of 80°C for Energy Saver Mode Level 1. Or: If the fusing temperature stays above 175°C for more than 180 seconds after selecting the power saver standby temperature of 145°C for Energy Saver Mode Level 1.	Sub-code 0A
During printing	If the fusing temperature is above 190°C for more than 180 seconds.	Sub-code 01
	If the fusing temperature is below 150 °C for more than 180 seconds.	Sub-code 06
	If the fusing temperature is below 140 °C for more than 1 second.	Sub-code 07
After printing	If the fusing temperature takes more than 20 minutes to return to 100°C when the machine goes into Energy Saver Mode Level 2. (After selecting fusing lamp Off for Energy Saver Mode Level 2.)	Sub-code 03
	Either: If the fusing temperature takes more than 20 minutes to go down to below 100 °C when the machine goes into the Energy Saver Mode Level 2. (After selecting the standby temperature of 80 °C for Energy Saver Mode Level 2.) Or: If the fusing temperature takes more than 5 minutes to go down to 165 °C after selecting the standby temperature for Energy Saver Mode Level 1.	Sub-code 04
At any time	If the fusing temperature reaches 250°C.	Sub-code 08

2.3 SYSTEM FEATURES

2.3.1 ENERGY SAVER MODES

In normal mode (during operation) or energy saver mode level 1, the main CPU monitors and controls the machine. The fusing lamp is either turned off or maintained at the standby temperature (80 °C), depending on the User Parameter Switch 05 bit 6 setting.

In Energy Saver Mode, level 2 (also known as the 2-watt Energy Saver Mode), the main CPU and DC power supplies are shut down. The Energy Saver CPU monitors the Energy Saver key, incoming calls, the document sensor, and the PC interface. When the Energy Saver CPU detects activity at one of these, it activates the +5V supply to start up the main CPU and other power supplies.

Detailed Descriptions

	Normal	Level 1	Level 2
Main CPU	ON	ON	OFF
Energy Saver CPU	OFF	OFF	ON
LCD/LED	ON	OFF	OFF
Energy Saver LED	OFF	ON	ON
+5V Power Supply	ON	ON	OFF
+24VM Power Supply	ON	ON	OFF
Fusing Lamp	ON	80 °C or OFF	OFF

The fusing lamp is turned off as the default setting for energy saver mode level 1.

When the energy saver timer expires, the machine automatically goes into Energy Saver Mode level 1 to keep the cooling fan going. When the fusing temperature has fallen down below a certain threshold, the machine enters Energy Saver Mode level 2.

Cross Reference

Energy saver timer initial setting: System Switch 0B, Bits 2 and 3
(1 minute, 3 minutes, 5 minutes, or Unlimited: Timer disabled)

Going to Level 2 Mode from Level 1 Mode

The machine will not go into Level 2 Energy Saver Mode if one of the following conditions exists:

- Either a TX/RX file is stored in the memory.
- SAF memory not empty
- Mechanical error(s)
- The NCU is off-hook

Manual Wake Up Conditions

While the machine is in Energy Saver Mode, either the Energy Saver CPU (Level 2) or the main CPU (Level 1) monitors signals from the following:

- Energy Saver key
- Document sensor
- Off-hook detector on the NCU

When the CPU detects a signal from one of these, it wakes up all the components and the machine enters normal operating mode, even during the Night Timer period.

After the operations are done, the machine returns to Energy Saver Mode, as explained previously.

NOTE: The machine does not detect cover open during the level 2 Energy Saver Mode.

2.3.2 AUTOMATIC SERVICE CALLS

Service Call Conditions

The machine makes an automatic service call when one of the following conditions occurs.

Service Call Conditions	Error Code	Sub-code (8003B5H)
Laser diode failure	9-20	21
Fusing lamp failure	9-22	01 to 0B
Hexagonal mirror motor failure	9-23	31 or 32
Power pack failure	9-29	51 to 59
Excessive jams in the scanner	None	None
Excessive jams in the printer	None	None
The PM counter has reached the threshold (60,000 prints)	None	None
The PM interval has expired	None	None

Detailed
Descriptions

Cross Reference

Service station number: Service Function 13

Troubleshooting: Chapter 7

2.3.3 SEP/SUB CODING

Overview

ITU-T introduced the following protocol signals in the T.30 recommendation in 1996. These signals enable confidential transmission and secured polling between machines produced by different manufacturers.

SEP (Selective Polling): This signal informs the other terminal of the polling ID to enable secured (ID) polling.

Up to 20 digits or characters can be sent in a SEP frame.

PWD (Password): This signal informs the other terminal of the password to enable extra security.

Up to 20 digits or characters can be sent in a PWD frame.

SUB (Sub-address): This signal informs a sub-address of a destination. Some fax servers use this information to route a received fax message to a specific address in the local network.

Up to 20 digits or characters can be sent in a SUB frame.

SID (Sender ID): This signal informs the other terminal of the sender ID to identify the transmitter.

Up to 20 digits or characters can be sent in a SID frame.

The ITU-T recommendation only clarifies the requirements for the transmitting terminal, and does not specify the requirements for the receiving terminal. How the receiving terminal treats these signals varies with receiver terminal and manufacturer.

NOTE: This machine is not capable of receiving above (SEP/PWD/SUB/SID) signals.

Selective Polling (SEP/PWD)

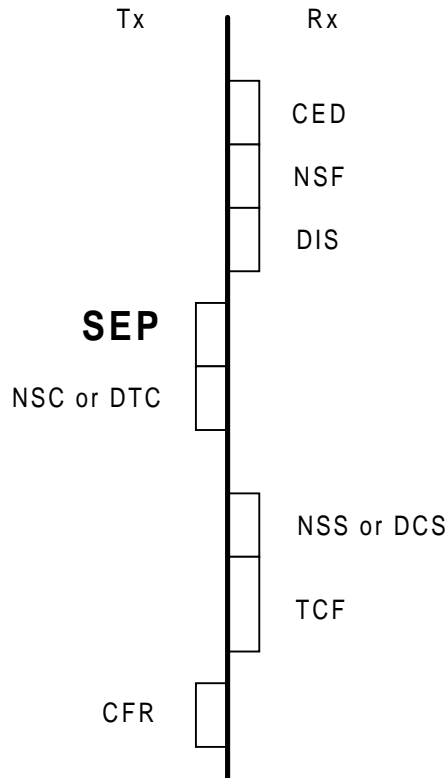

H545D560.WMF

Detailed Descriptions

SEP Signal:

When the RX terminal receives the SEP signal with the NSC or DTC signal, the RX terminal switches over to secured polling transmission using the SEP ID. The SEP (Selective polling) signal must contain four digits as an ID.

The RX terminal automatically disconnects the line when any of the following conditions occur (Error Code 0-15):

- When the SEP ID is other than four digits
- When anything other than numbers is included in the ID

The communication is free polling when the programmed SEP ID is 0000.

PWD Signal:

When the PWD (password) and the SEP signals are transmitted together, the PWD programmed becomes an ID code for the stored ID override.

NOTE: SEP and PWD reception is disabled for this machine.

The machine automatically disconnects the line when it receives the SEP or PWD signal.

Sub-address (SUB/SID)

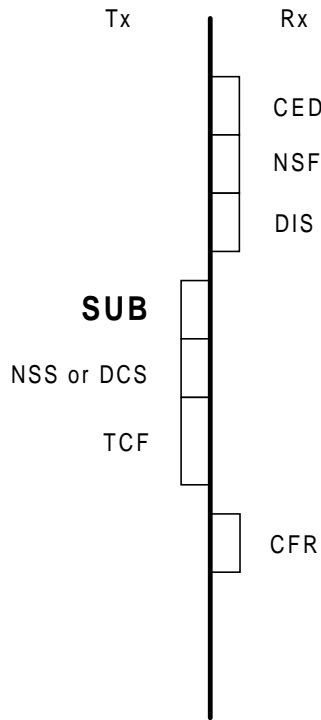

H545D561.WMF

SUB Signal:

The SUB (sub-address) signal transmitted from the TX terminal contains a confidential ID. A stored message can be printed using the SUB ID as a confidential ID.

The SUB ID must contain four digits. The receiving terminal automatically disconnects the line when any of the following conditions occur (error code 0-15):

- When the SUB ID is other than four digits
- When anything other than numbers is included in the ID
- When a confidential ID is not programmed in the RX terminal and when the transmitted SUB ID is 0000

A stored message can be printed using the (normal) confidential ID stored in the machine when the SUB ID sent from the transmitter is 0000.

SID Signal:

When transmitted together with the SUB signal, the SID programmed is an ID code for the confidential ID stored override.

NOTE: SID reception is disabled for this machine.

This machine automatically disconnects the line when it receives a SID signal.

Cross-reference: Section 4.2 Bit Switches

Communication Bit Switch 17 Bit 1: SUB signal reception.

2.3.4 PAGE SEPARATION AND DATA REDUCTION

Incoming pages that are only slightly longer than the copy paper may be reduced in the sub-scan direction. Whether or not this happens depends on the settings of printer switches 04 and 05.

Reduction Enabled

If bit 0 of printer switch 03 is at 1 (Enabled), the data will be reduced in the page memory to fit on the copy paper. However, data will only be reduced if the length of the incoming page is ± 5 mm shorter than a certain maximum length. The maximum reducible incoming page length depends on the copy paper size and the reduction ratio stored for that paper size in printer switches 04 and 05.

Each paper size can be programmed with a separate reduction ratio. In each of the two bit switches, there is one bit for each possible paper size. The combination of the bit settings determines the ratio for that paper size.

Bit No. Switch No.	Bit 7 Not used	Bit 6 Not used	Bit 5 Legal	Bit 4 F4	Bit 3 A4	Bit 2 Letter	Bit 1 Not used	Bit 0 A5 sideways
Sw 04	0: 4/3		1: 4/3		0: 8/7		1: 12/11	
Sw 05	0:		0:		1:		1:	

The following table shows the maximum reducible incoming page length for each copy paper size. All lengths are in millimeters. The factory setting of the reduction ratio is 4/3.

Asia/Taiwan Model

Paper Type	Printable Page Length	Maximum Reducible Incoming Page Length		
		Ratio = 4/3	Ratio = 8/7	Ratio = 12/11
A5 Sideways	147.8 mm	190.1 mm	162.9 mm	155.3 mm
A4	296.9 mm	388.8 mm	333.2 mm	318.2 mm
F4	330.1 mm	433.2 mm	371.2 mm	354.3 mm

Incoming pages that are longer than the maximum length will not be reduced, but will print on two pages and be treated in accordance with the setting of bit 1 of printer switch 00. If this bit is 1, the bottom few lines of the page will continue from where the first page left off. If it is 0, the next page continues from where the previous page left off.

Reduction Disabled

If bit 0 of printer switch 03 is at 0 (Disabled), the data will not be reduced. In addition, if the incoming page is up to x mm longer than the copy paper, the excess portion will not print. The setting of bits 4 to 7 of printer switch 03 determine the value of x, somewhere between 0 to 15 mm.

Hex value	Value of X
0	0
0	1
and so on until	
F	15

Messages more than x mm longer than the copy paper will print out on two pages in accordance with the setting of bit 1 of printer switch 00, as explained earlier.

2.3.5 MEMORY RECEPTION CONDITIONS

User parameter switch 05 bit 1 allows the user to select how to treat an incoming message that is without RTI or CSI.

User parameter switch 05 Bit-1:

Memory reception if no RTI or CSI received 0: Possible, 1: Impossible

If 0 is selected, the machine receives all messages regardless of RTI and CSI.

If 1 is selected (this is the default setting), the user parameter setting works in combination with the following bit switch.

System Bit Switch 11 Bit 6:

Conditions for memory reception if no RTI or CSI is received.

0: Impossible; memory reception is available only after receiving the RTI or CSI.

1: Memory reception is possible if there is no mechanical (printer) error.

The default setting is 1. The default setting means that if the printer is working, it will receive all messages. However, when there is a mechanical error in the printer, the machine rejects such a message because no trace of the sender will be stored in the machine.

2.3.6 V.8/V.34 PROTOCOL

Please refer to the V.8/V.34 Training Manual for overall information about V.8/V.34 protocol.

This section explains only functions that are specific to this machine.

Data Rate Change Procedure

Shift-down Request from Receiving Terminal

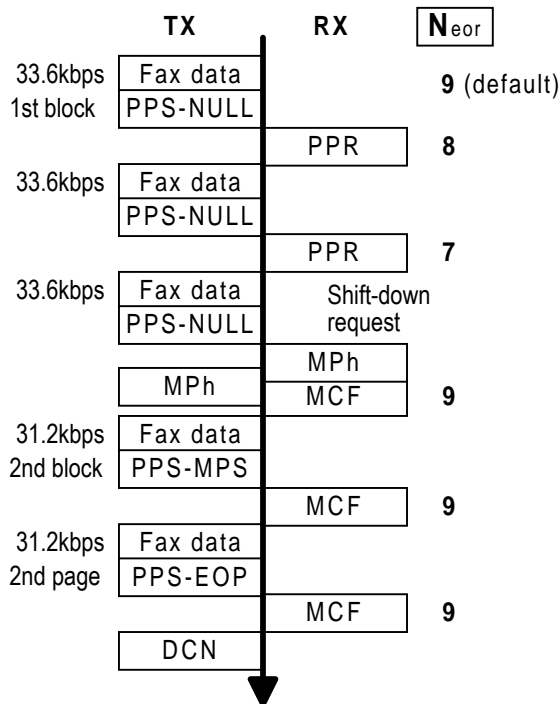

H551D505.WMF

- N_{eor} is the number of frame re-transmissions until the TX terminal sends DCN to terminate the communication. This number is fixed at "9", and is not adjustable.

If this machine has sent two PPRs for one ECM block, it will request one step shift-down to the sender terminal in the next control channel.

Shift-down Request from Sending Terminal

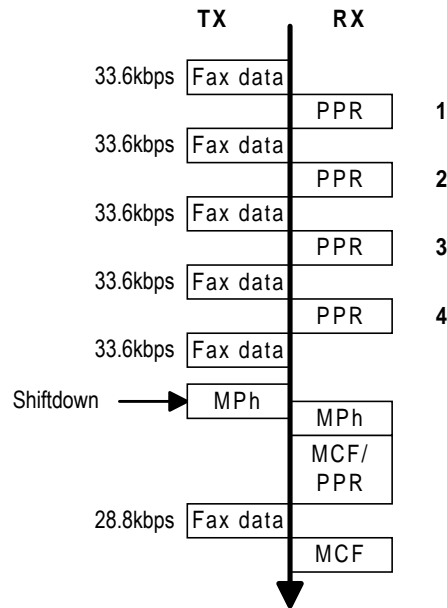

H545D563.WMF

If this machine has received four PPRs for one ECM block, it will request a two-step shift-down to the receiving terminal in the next control channel.

Shift-up Request from Receiving Terminal

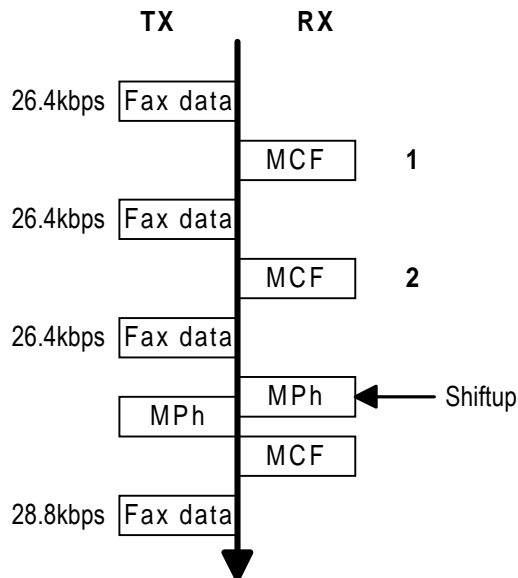

H545D564.WMF

If this machine has sent two consecutive MCFs and detected a good line condition, it will request a one step up-shift to the sender terminal in the next control channel.

Detailed Descriptions

2.3.7 BLANK SHEET DETECTION

When the machine scans the document for transmission, it counts the black pixels. If the number of black pixels is below a certain threshold, the machine displays an error message (BLANK DOCUMENT).

Immediate transmission

When the machine detects one or more blank pages, the LCD displays an error message for 20 seconds after transmission.

Memory transmission

When the machine detects one or more blank pages, the LCD displays an error message for 20 seconds after completing memory storage.

Cross-reference: Section 4.5 Service RAM Address

8002E8 Error display condition

The setting of this RAM address determines when the machine displays the “blank paper detected” error message.

01H: If the first page is blank

02H: If all the pages are blank

03H: If at least one of the pages is blank

2.4 PCBS

2.4.1 FCU

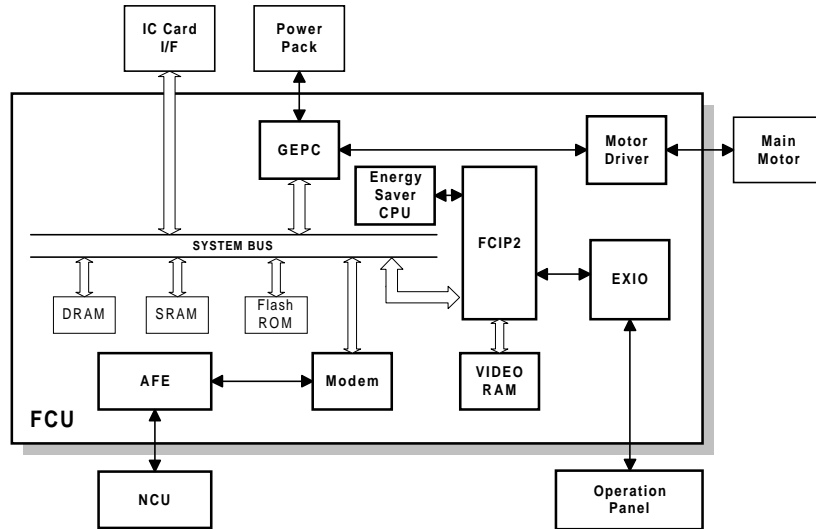

H545D701.WMF

The FCU (Facsimile Control Unit) board contains the FCIP2 (Facsimile Control and Image Processor), DRAM, SRAM, Flash ROM, and video processing memory, and it controls the entire system. FCIP2

- CPU
- Data compression and reconstruction (DCR)
- Digital image processor
- Laser interface
- DMA controller
- Clock generation
- Stepper motor control
- DRAM backup control
- Fusing lamp control

ROM

- 1MB (8 Mbits) flash ROM for system software storage

DRAM

- 2 MB DRAM shared between the Line Buffer (124 KB), ECM Buffer (128 KB), Page Memory (1156 KB), System RAM (128KB), and SAF memory (512 KB)

SRAM

- 32 KB SRAM for system and user parameter storage, backed up by the battery on the FCU

Video SRAM

- 8 KB SRAM for video processing

Detailed Descriptions

Modem (Rockwell R288F)

- V.21, V.27ter, V.29, V.17, V.33 (Ricoh mode only), and V.34 modems

GEPC

- Power pack and main motor control

Oscillators

- 29.952 MHz oscillator for system, scanner and printer clock generation
- 32.768 MHz oscillator for the real time clock. The battery on the FCU backs this up
- 56.448 MHz oscillator for the R288F modem clock
- 4.19 MHz oscillator for the DTMF receiver clock
- 8.00 MHz oscillator for the Energy Saver CPU clock
- 8.00 MHz oscillator for the GEPC clock

EXIO (External I/O)

- Serial interface to the operation panel and optional paper feed units
- Parallel interface to the motors, clutches, sensors, and other electrical components

Switch

Item	Description
SW1	Switches the backup battery on/off

Energy Saver CPU

- 4-bit CPU for controlling the machine during energy saver mode.

Analog circuit with HIC (AFE – Analog Front End)

- 2-4 wire switching
- Filters and amplifiers
- Monitor speaker driver

DC/DC Converters

- +5V, +12V, and -9V generation

DRAM Backup

- +5VD generation for DRAM (SAF memory) backup

The FCU (Facsimile Control Unit) board contains the FCIP2 (Facsimile Control and Image Processor), DRAM, SRAM, Flash ROM, and video processing memory, and it controls the entire system.

2.4.2 PSU

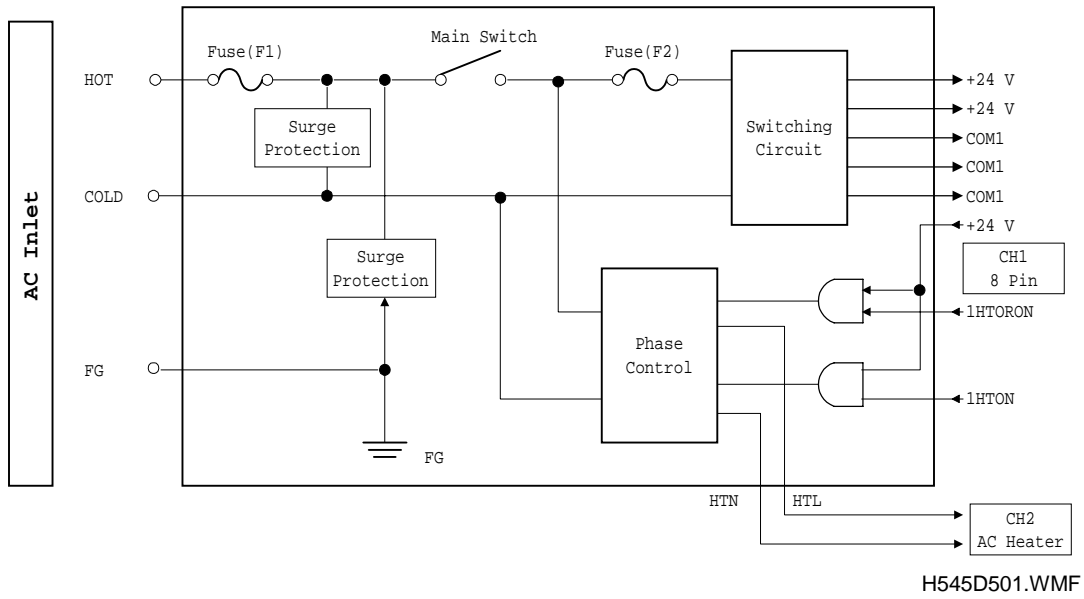

Detailed Descriptions

- +24Vdc generation
- Fusing lamp AC power supply and control

2.4.3 NCU (USA/TAIWAN)

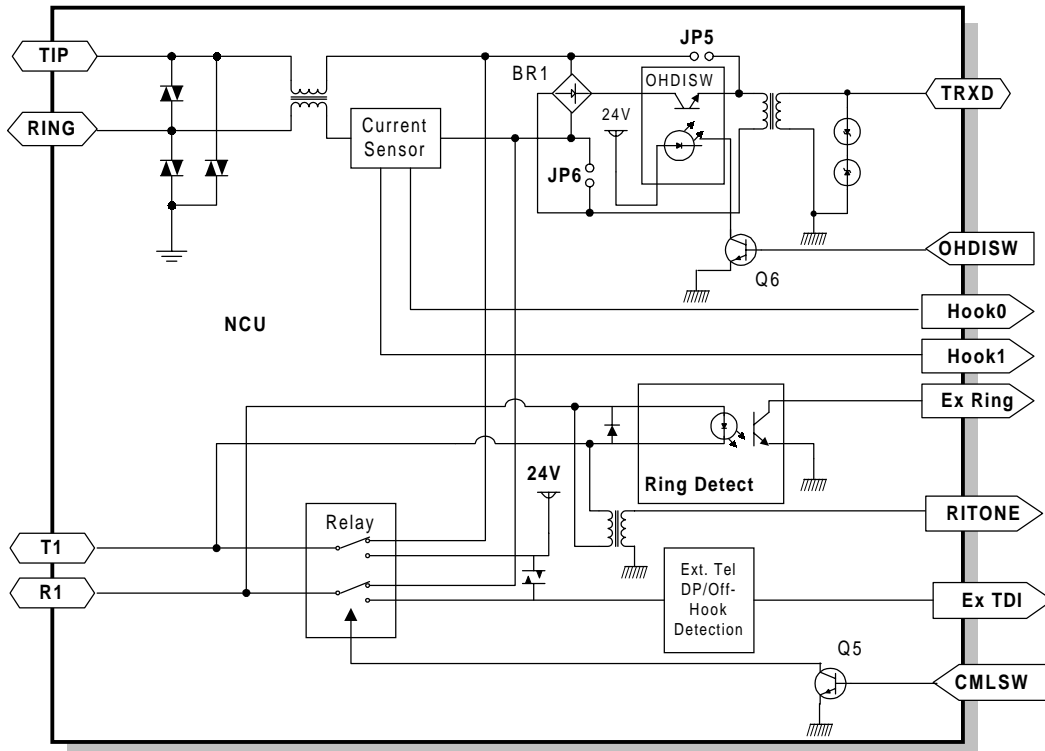

H545D550.WMF

Jumpers

Item	Description
JP5	These jumpers should be shorted when the machine is connected to a dry line for back-to-back tests.
JP6	
BR1	Also remove BR1 when the machine is connected to a dry line.

3. INSTALLATION

3.1 INSTALLING THE MACHINE

Refer to the Operator's Manual for information about the installation environment and instructions on how to install and set up the machine.

3.2 INITIAL PROGRAMMING

Items to Program (Service Level)	Function No.
Country code (NCU parameter 00)	Function 08
Country code (System switch 0F)	Function 01
Protocol requirements (G3 switch 0B)	Function 01
PABX access code (RAM address 8000BB)	Function 06
PABX access method (RAM address 8000AD)	Function 06
Machine's serial number	Function 14
Service station's fax number	Function 13
PM call (System switch 01- bit 0)	Function 01
Periodic service call (RAM address 800266)	Function 06

Items to Program (User Administrator Level)	Function No.
Clock	Function 91
Initial programming items	Function 61
On/off switches	Function 62
Display/report language	Function 93
Fusing power control during energy saver mode (User parameter switch 05 - bit 6)	Function 63









3.3 INSTALLING OPTIONAL UNITS

An optional paper feed unit is available for this machine. Refer to the Operator's Manual for how to install and set up.

4. SERVICE TABLES AND PROCEDURES







4.1 SERVICE LEVEL FUNCTIONS

In this section, the following symbols refer to frequently used keys:



-  - Start key
-  - Stop key
-  - Function key
-  - Yes key
-  - No key
-  - Up arrow key
-  - Down arrow key
-  - Right arrow key
-  - Left arrow key

Service Tables







4.1.1 BIT SWITCH PROGRAMMING (FUNCTION 01)

1.      
then immediately press 

FUNCTION KPAD/NEXT>
 ■■SERVICE FUNCTIONS

2.   
Bit 7 is on the left, and bit 0 on the right.

SERVICE Y/NEXT>
 01 BIT SW

3. Scroll through the bit switch menu using  or 
Example: To see the communication switches:
 x 3
 Then scroll through the bit switches.
 Increment bit switch: 
 Decrement bit switch: 
Example: Display bit switch 3:  x 3

COM DF : 0000 0000
 BITSW 00: 0000 0000

4. Adjust the bit switch.
Example: To change the value of bit 7,
 press 

COM DF : 0000 0000
 BITSW 03: 0000 0000

5. Either:
 - Adjust more bit switches - go to step 3.
 - Finish - 

4.1.2 SYSTEM PARAMETER LIST (FUNCTION 02)

The format of the list is as follows:

1. **Function** 6 1 9 9 8 ,
then immediately press **Yes**
2. 0 2 **Yes**
3. Finish: **Function**

```
FUNCTION  KPAD/NEXT>
■■■■SERVICE FUNCTIONS
```

```
START
PARAMETER LIST
```

4.1.3 ERROR CODE DISPLAY (FUNCTION 03)

1. **Function** 6 1 9 9 8 ,
then immediately press **Yes**
2. 0 3 **Yes**
3. Either:
Scroll through the error codes using or
Finish - **Function**

```
FUNCTION  KPAD/NEXT>
■■■■SERVICE FUNCTIONS
```

```
ERROR CODE  <>
1-01 JAN 01 17:30
```

4.1.4 SERVICE MONITOR REPORT (FUNCTION 04)

1. **Function** 6 1 9 9 8 ,
then immediately press **Yes**
2. 0 4 **Yes**
3. Finish: **Function**

```
FUNCTION  KPAD/NEXT>
■■■■SERVICE FUNCTIONS
```

```
START
SERVICE REPORT
```

4.1.5 GROUP 3 PROTOCOL DUMP (FUNCTION 05)

1. **Function** 6 1 9 9 8 ,
then immediately press **Yes**
2. 0 5 **Yes**
3. 0
- 4.
5. Finish: **Function**

```
FUNCTION  KPAD/NEXT>
■■■■SERVICE FUNCTIONS
```

```
0-G3      1-PC
```

```
START
PROTOCOL DUMP
```

4.1.6 PC PROTOCOL DUMP (FUNCTION 05)

1. **Function**
then immediately press
2.
3.
4.
5. Finish: **Function**

```
FUNCTION  KPAD/NEXT>
■■■■SERVICE FUNCTIONS
```

```
0-G3      1-PC
```

```
START
PC PROTOCOL DUMP
```

4.1.7 RAM DISPLAY/REWRITE (FUNCTION 06)

1. **Function**
then immediately press
2.
3.
4. Input the address that you wish to see.
Example: Address 800020

Note: If you wish to move the cursor, press .
5. If you wish to change the data, type in the new data.
Example: 80, press
Note: If you wish to move the cursor, press .
6. Either:
 - View more addresses - go to step 4.
 - Finish - **Function**

```
FUNCTION  KPAD/NEXT>
■■■■SERVICE FUNCTIONS
```

```
0-MEM.R/W 1-MEM.DUMP
```

```
ADDRESS = 000000
DATA     = 00
```

```
ADDRESS = 800020
DATA     = 20
```

```
ADDRESS = 800020
DATA     = 80
```

Service Tables

4.1.8 RAM DUMP (FUNCTION 06)

1. **Function**
then immediately press
2.

```
FUNCTION  KPAD/NEXT>
■■■■SERVICE FUNCTIONS
```

```
0-MEM.R/W 1-MEM.DUMP
```

3.

```
MEMORY DUMP  START/N
ADD.000000 - 0000FF
```

4. Enter the first four digits of the start and end addresses. For example, enter "8000" for the start address 800000(H), and enter 8001 for the end address 8001FF(H). Then, press "Start" to print the dump list.

```
MEMORY DUMP  START/N
ADD.800000 - 8001FF
```

5. Finish:

4.1.9 COUNTER DISPLAY/REWRITE (FUNCTION 07)

1.
then immediately press

```
FUNCTION      KPAD/NEXT>
■■SERVICE FUNCTIONS
```

2.

```
0-COUNTER    1-PM
2-TONER
```

3. Either:
Check the transmitted, received, scanned and printed page counters, and the printer and scanner jam counters - press

```
TX :012345
RX :012345
```

(To see the scanned and printed page counters, press .

```
SCN :012345
PRT :012345
```

To see the printer and scanner jam counters, press again.)

```
S.JAM :000000
P.JAM :000000
```

Check the PM counter - press

```
PM COUNTER:001234
```

Check the TONER counter - press
This is the number of prints made with the current cartridge.

```
TONER      :001234
```

4. To change the contents of a counter, input the new value, then press .

5. To finish:

4.1.10 NCU PARAMETERS (FUNCTION 08)

1.
then immediately

FUNCTION	KPAD/NEXT>
■■SERVICE	FUNCTIONS

2.

3.

0-NCU	1-MODEM
2-DTMF	3-V8

4. Scroll through the parameters using or . If you want to change a value, enter the new value at the keypad, then press .

NCU	KPAD/<>
NO.04 =	005

Example: Set NCU parameter 04 to 005.

5. To finish: .

NOTE: Parameter CC is the Country Code, Parameter 01 is the TX level. Refer to section 4.3 for full details on NCU parameters.

Service Tables

4.1.11 MODEM TEST (FUNCTION 08)

1.
then immediately press

FUNCTION	KPAD/NEXT>
■■SERVICE	FUNCTIONS

2.

3.

0-NCU	1-MODEM
2-DTMF	3-V8

4. Scroll through the available tests using or .

5.

6. To stop the test:

MODEM TEST	START/<>
800 Hz	

7. To finish: .

4.1.12 DTMF TONE TEST (FUNCTION 08)

1.
then immediately press

FUNCTION	KPAD/NEXT>
■■SERVICE	FUNCTIONS

2.

0-NCU	1-MODEM
2-DTMF	3-V8

3.

4. Scroll through the available tests using or .

- 5.
6. To stop the test:
7. To finish:

DTMF TEST	START / <>
TONE 0	

4.1.13 V.8 MODEM TEST (FUNCTION 08)

1.
then immediately press
- 2.
- 3.
4. Scroll through the available tests using or
- 5.
6. To stop the test:
7. To finish:

FUNCTION KPAD/NEXT>
■■SERVICE FUNCTIONS

0-NCU	1-MODEM
2-DTMF	3-V8

V8 TEST	START
ANSAM	

4.1.14 V.34 MODEM TEST (FUNCTION 08)

1.
then immediately
- 2.
- 3.
4. Scroll through the available tests using or
- 5.
6. To stop the test:
7. To finish:

FUNCTION KPAD/NEXT>
■■SERVICE FUNCTIONS

0-NCU	1-MODEM
2-DTMF	3-V8

4-V34	5-RINGER
-------	----------

V34 SYMBOL RATE	Y / <>
2400SYM/S	

4.1.15 RINGER TEST (FUNCTION 08)

1.
then immediately press
2.
3.
4.
5. To stop :
6. To finish:

FUNCTION KPAD/NEXT> ■■SERVICE FUNCTIONS	
0-NCU	1-MODEM
2-DTMF	3-DETECT
4-V34	5-RINGER
RINGER	START

4.1.16 OPERATION PANEL TEST (FUNCTION 09)

1.
then immediately press
2.
3.
4.
5. To stop the test, press
6. To finish:

FUNCTION KPAD/NEXT> ■■SERVICE FUNCTIONS	
0-LED/LCD	
LED/LCD	START

Service Tables

4.1.17 LED ARRAY TEST (FUNCTION 10)

1.
then immediately press
2.
3.
4.
5. To stop the test, press
6. To finish:

FUNCTION KPAD/NEXT> ■■SERVICE FUNCTIONS	
0-LAMP	1-ADF
LAMP	START 000

4.1.18 ADF TEST (FUNCTION 10)

1.
then immediately press
2.
3.
4. Place a document in the feeder,
then press .
5. To stop the test, press
6. Finish:

FUNCTION KPAD/NEXT> ■■SERVICE FUNCTIONS
--

0-LAMP 1-ADF

START ADF

4.1.19 PRINTER TEST PATTERNS (FUNCTION 11)

1.
then immediately press
2.
3.
4. Press a key from to .
5. Press .
- A test pattern is printed.
6. To finish:

FUNCTION KPAD/NEXT> ■■SERVICE FUNCTIONS
--

0-PATTERN 1-MECH

PATTERN PRINT KPAD 0-7

4.1.20 PRINTER MECHANISM TEST - FREE RUN (FUNCTION 11)

1.
then immediately press
2.
3.
4.
5. To stop the test, press
6. To finish:

FUNCTION KPAD/NEXT> ■■SERVICE FUNCTIONS
--

0-PATTERN 1-MECH

START MECH

NOTE: Make sure that there is some paper in the cassette before starting the test.

4.1.21 RAM TESTS (FUNCTION 12)

1. **Function** **6** **1** **9** **9** **8**
then immediately press **Yes**
2. **1** **2** **Yes**
3. Either:
 Test the SRAM: Press **0** **↕**
 Test the DRAM: Press **1** **↕**
 Test the SAF card: Press **2** **↕**

FUNCTION KPAD/NEXT>	
■■SERVICE FUNCTIONS	

0 - SRAM	1 - DRAM
2 - SAFCARD	3 - M→R

If the test is successful, the display shows "OK".
 If the test is unsuccessful, the display shows "ADDRESS=".

4. To finish: **No** **Function**.

4.1.22 SOFTWARE DOWNLOAD (FUNCTION 12)

Instead of replacing an EPROM to update the machine's software, use this procedure to update the software in the Flash ROM. This function copies software from an external medium to the Flash ROM on the FCU inside the machine. The external medium for the new software can be another FCU or an EPROM board.

1. Turn off the machine.

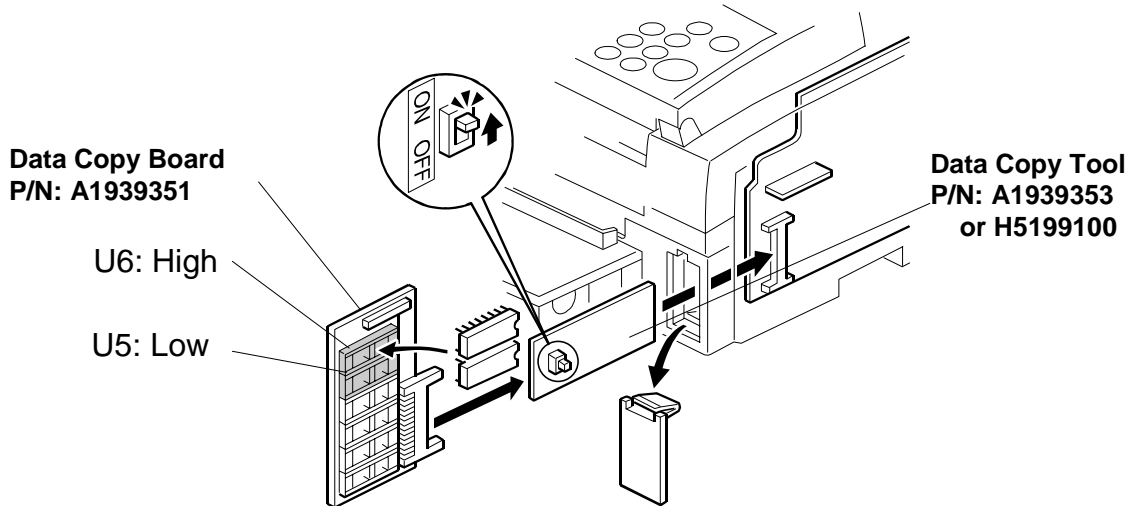

H545M501.WMF

2. Insert the Flash/SRAM Copy Tool into the IC card slot, then connect the FCU or EPROM board with the new software as shown in the above diagram (the EPROM board is shown here).



NOTE: The switch on the tool must be at the **ON** position.

Service Tables

3. Turn on the machine.

4.      
then immediately press 

FUNCTION KPAD/NEXT> ■■SERVICE FUNCTIONS
--

5.   

0-SRAM	1-SAF
2-SAFCARD	3-M->R

6.  

7. 
If the software downloads successfully, the display shows "OK".

OK!! COPY MACH <- FLROM

If the software download fails, the display shows "CANNOT PROGRAM".

COPYING CANNOT PROGRAM

8. To finish, press .

9. Turn off the machine and disconnect the tool. Then turn the machine back on.

10. Print out the system parameter list and check the ROM version on it.

4.1.23 SOFTWARE UPLOAD (FUNCTION 12)

This function copies the software from the FCU inside the machine to an external FCU.

1. Turn off the machine.



2. Connect the Flash/SRAM Copy Tool and an FCU as shown in the previous section.

NOTE: The switch [D] on the tool must be at the **OFF** position.

3. Turn on the machine.

4.      
then immediately press 

FUNCTION KPAD/NEXT> ■■SERVICE FUNCTIONS
--

5.   

0-SRAM	1-SAF
2-SAFCARD	3-M->R

6.  

If the software uploads successfully, the display shows "OK".

OK!!
COPY MACH -> FLROM

If the software upload fails, the display shows "NG".

NG!!
COPY MACH -> FLROM

7. Finish : 

8. Turn off the machine and disconnect the tool. Then turn the machine back on again.

4.1.24 SRAM DATA DOWNLOAD (FUNCTION 12)

This function copies all the data stored in the SRAM on an external FCU to the FCU inside the machine. Use this after replacing a damaged FCU to save any previously programmed settings in the damaged FCU.

Service Tables

1. Turn off the machine.

2. Connect the Flash/SRAM Copy Tool and the damaged FCU.

NOTE: The setting of the switch on the tool will not affect the result of this procedure.

3. Turn on the machine.

FUNCTION KPAD/NEXT>
■■SERVICE FUNCTIONS

4.      

then immediately press 

0-SRAM 1-SAF
2-SAFCARD 3-M->R

5.   

6.  

OK!!
COPY MACH <- SRAM

7. 

If the SRAM data downloads successfully, the display shows "OK".

If the SRAM download fails, the display shows "CANNOT PROGRAM".

COPYING
CANNOT PROGRAM

8. Finish : 

9. Turn off the machine and disconnect the tool. Then turn the machine back on.

4.1.25 SERVICE STATION FAX NUMBER (FUNCTION 13)

- 1.
then immediately press

```
FUNCTION KPAD/NEXT>
■■SERVICE FUNCTIONS
```

- 2.

```
S.S. NO.                KPAD
■■■■■■■■■■■■■■■■■■■■
```

- 3. Input the telephone number of the service station that will receive Auto Service calls from this machine.

To erase the telephone number: press

```
S.S. NO.                KPAD
212-5555■■■■■■■■■■■■
```

- 4. If the display is correct:

4.1.26 SERIAL NUMBER (FUNCTION 14)

- 1.
then immediately press

```
FUNCTION KPAD/NEXT>
■■SERVICE FUNCTIONS
```

- 2.

```
SERIAL #                KPAD
■■■■■■■■■■■■■■■■■■■■
```

- 3. Enter the serial number at the keypad.
To correct a mistake:

```
SERIAL #                KPAD/Y/N
RICOH 1234567
```

- 4. If the display is correct:

- 5. Finish:

4.2 BIT SWITCHES

⚠ WARNING
 Do not adjust bit switches described as "Not used", as this may cause the machine to malfunction or to operate in a manner that is unacceptable under local regulations. Such bits are only for use in other areas, such as Japan.

NOTE: This manual does not list default settings for bit switches. Refer to the System Parameter List.

4.2.1 SYSTEM SWITCHES

System Switch 00		
No	FUNCTION	COMMENTS
0	RAM Reset	
	Bit 1	Bit 0
	Reset Level	
	0	0
	0	1
1	1	0
	1	1
	Not used	
		<p>Reset Level 3: Erases all image data files stored in the SAF memory and communication files (e.g. substitute RX files). This is the recommended setting when the SAF requires clearing.</p> <p>Reset Level 2: This level erases the following items in addition to those erased by Reset Level 3: own telephone number, bit switches (excluding country code), RTI/TTI/CSI, report data, programmed telephone numbers (Quick/Speed/Groups, service station, etc.), NCU parameters, and personal codes.</p> <p>After erasing, the machine automatically changes these two bits back to 0.</p> <p>Important: When RAM reset level 2 is done, the machine refers to the bit switch country code (System bit switch 0F: functional settings) and automatically changes the NCU country code (NCU parameter: RAM 807F00) to the same code.</p> <p>No reset: Normal operation</p> <p>Cross-reference RAM Reset Level 1 (Factory reset): Change the RAM address data from 800005(H) to FF(H), then turn the machine off and on. In addition to those items erased by Reset Level 2, the clock, country code (the default country code is for the U.S.), scan margin settings and print registration settings are erased.</p>

Service Tables

System Switch 00		
No	FUNCTION	COMMENTS
2	Technical data printout on Journal 0: Disabled 1: Enabled	1: Instead of a personal code, the Journal lists the following data for each analog G3 communication. E.g. 32 V34 288 M 01 00 03 02 First number: Symbol rate (V.34 only) Second number: Final modem type used Third number: Final data rate (for example, 288 means 28.8 KBPS) Fourth number: M means modem EQM. / L means RX level. Fifth and sixth number: Line quality data. This is either a measurement of the error rate or the RX level, depending on the bit 3 setting below. (An M on the report indicates that it is error rate, and an L indicates RX level.) The left-hand figure is the high byte and the right-hand figure is the low byte (refer to the note after this table for how to read the RX level). If it measures the error rate, a larger number means more errors. Seventh number (RX mode only): Total number of error lines that occurred during non-ECM reception. Eighth number (RX mode only): Total number of burst error lines that occurred during non-ECM reception. The seventh and eighth numbers are fixed at 00 for transmission records and ECM reception records.
3	Line quality data output method 0: Error rate measurement during image data transmission 1: Rx level	This bit determines the data type printed in the Journal when bit 2 (above) enables a technical data printout.
4	Line error marks 0: Disabled 1: Enabled	If this bit is 1, a mark will be printed on the left edge of the page at any place where a line error occurred in the data. A noisy line causes such errors, for example.
5	Communication parameter display 0: Disabled 1: Enabled	This is a faultfinding aid. The LCD shows the key parameters (see the next page). This is normally disabled because it cancels the CSI display for the user. Be sure to reset this bit to 0 after testing.
6	Protocol dump list output 0: Disabled 1: Enabled	This is only for communication troubleshooting. It shows the content of the transmitted facsimile protocol signals. Always reset this bit to 0 after testing. The setting of system switch 09 bit 6 determines the types of communication that the list is printed after.
7	Not used	Do not change these settings.

How to calculate the RX level listed on the Journal (when bit 2 of system switch 00 is set to 1)

Example: 32 V34 288 L 01 00 00 00

The four-digit hexadecimal value (N) after L indicates the RX level.
The high byte is given first, followed by the low byte. Divide the decimal value of N by -16 to get the RX level.

In this above example, the decimal value of N (=0100[H]) is 256.
So, the actual RX level is 256/-16 = -16 dB.

Communication Parameters

Mode	DCS: ITU-T standard	NSS: Non-standard G3
Modem rate	336: 33600 BPS 312: 31200 BPS 288: 28800 BPS 264: 26400 BPS 240: 24000 BPS 216: 21600 BPS 192: 19200 BPS	168: 16800 BPS 144: 14400 BPS 120: 12000 BPS 96: 9600 BPS 72: 7200 BPS 48: 4800 BPS 24: 2400 BPS
Communication mode	ECM: With ECM SSC: Using SSC NML: With no ECM, SSC	
Compression mode	MMR: MMR compression MR: MR compression MH: MH compression	
Resolution	F: Fine, transmitted at 8 x 15.4 dots per mm D: Detail, transmitted at 8 x 7.7 dots per mm S: Standard, transmitted at 8 x 3.85 dots per mm	
I/O rate	0: 0 ms/line 10: 10 ms/line 25: 2.5 ms/line 20: 20 ms/line 5: 5 ms/line 40: 40 ms/line "40" is displayed while receiving a fax message using AI short protocol.	
Width and reduction	A4: A4 (8.3"), no reduction B4: B4 (10.1") no reduction	

Service Tables

System Switch 01		
No	FUNCTION	COMMENTS
0	PM call 0: Disabled 1: Enabled	This bit switch determines whether the machine will send an Auto Service Call to the service station when it is time for PM.
1-7	Not used	Do not change these settings.



System Switch 02		
No	FUNCTION	COMMENTS
0	Memory file transfer 0: Disabled 1: Enabled	1: All messages in the memory (including confidential RX messages) are sent to the fax number, which is programmed as the service station. Always reset this bit to zero after transfer. Cross-reference Service station number programming: Function 13
1-2	Not used	Do not change these settings.
3	Substitute reception file printout 0: Full size only 1: Reduce to the paper size	1: If the paper in the cassette is smaller than the received message, the machine reduces the incoming message to the paper size before printing.
4-5	Not used	Do not change these settings.
6	Memory read/write by RDS	(0,0): All RDS systems are always locked out. (0,1), (1,0): At any time, an RDS system can access the machine. (1,1): At any time, an RDS system can access the machine.
7	Bit 7 6 Setting	
	0 0 Always disabled	
	0 1 User selectable	
	1 0 User selectable	
	1 1 Always enabled	

System Switch 03		
No	FUNCTION	COMMENTS
0 to 7	Length of time that RDS is temporarily switched on when bits 6 and 7 of System Switch 02 are set to "User selectable"	00 - 99 hours (BCD). This data is only valid if bits 6 and 7 of System Switch 02 are set to "User selectable". The default setting is 24 hours.

System Switch 04		
No	FUNCTION	COMMENTS
0-2	Not used	Do not change these settings.
3	Dedicated transmission parameter programming 0: Disabled 1: Enabled	Set this bit to 1 before changing any dedicated transmission parameters.
4	Inclusion of the Start key in Keystroke Programs 0: Not needed 1: Needed	0: The user does not need to press the Start key when operating a keystroke program.
5	Not used	Do not change the settings.
6	CSI programming level 0: User level 1: Service level	1: Only a service function can program the CSI.
7	Telephone line type programming mode 0: User level 1: Service level	1: Only a service function can program the telephone line type selection.

System Switch 05		
No	FUNCTION	COMMENTS
0-1	Not used	Do not change these settings.
2	Display of both RTI and CSI on the LCD 0: Disabled 1: Enabled	1: Both RTI and CSI will be displayed alternately on the LCD.
3-7	Not used	Do not change these settings.

System Switch 06		
No	FUNCTION	COMMENTS
0	Use of the Stop key during memory transmission 0: Disabled 1: Enabled	1: The Stop key can be used to halt memory transmissions. However, users might accidentally cancel another person's memory transmission in progress.
1-3	Not used	Do not change these settings.
4	Use of the Stop key during memory transmission 0: Disabled 1: Enabled	1: The Stop key can be used to halt memory transmissions. After pressing the Stop key, a message (STOP & CLR FILE?) appears on the LCD.
5-7	Not used	Do not change these settings.

Service Tables

System Switch 07 - Not used (do not change any of these settings)
System Switch 08 - Not used (do not change any of these settings)

System Switch 09		
No	FUNCTION	COMMENTS
0	Not used	Do not change this setting.
1	Inclusion of communications in the Journal when no image data was exchanged. 0: Disabled 1: Enabled	0: The Journal lists communications that reached phase C (message TX/RX) of the T.30 protocol. 1: The Journal lists communications that reached phase A (call setup) of T.30 protocol. This includes telephone calls.
2	Automatic error report printout 0: Disabled 1: Enabled	0: Error reports are not printed. 1: Error reports will print automatically after all failed communications, excluding polling reception and immediate transmissions.
3	Print error code on error report 0: No 1: Yes	1: Error codes are printed on the error reports.
4	Listing of Confidential IDs on the Personal Code List 0: Disabled 1: Enabled	1: Confidential IDs registered with Personal Codes by the users will appear on the Personal Code List.
5	Power failure report 0: Disabled 1: Enabled	1: A power failure report automatically prints after the power is switched on if a fax message disappears from memory when the power was turned off last.

System Switch 09		
No	FUNCTION	COMMENTS
6	Conditions for printing the protocol dump list 0: Print for all communications 1: Print only when there is a communication error	This switch becomes effective only when system switch 00 bit 6 is set to 1. 1: Set this bit to 1 when you wish to print a protocol dump list only for communications with errors.
7	Priority given to various types of remote terminal ID when printing reports 0: RTI > CSI > Dial label > Tel. Number 1: Dial label > Tel. number > RTI > CSI	This bit determines which set of priorities the machine uses when listing remote terminal names on reports. Dial Label: The name stored with the Quick/Speed Dial number by the user.

System Switch 0A		
No	FUNCTION	COMMENTS
0-3	Not used	Do not change these settings.
4	Dialing on the ten-key pad when the handset is off-hook 0: Disabled 1: Enabled	1: The user can dial on the ten-key pad when the handset is off-hook.
5	On-hook dial 0: Disabled 1: Enabled	0: On-hook dial is disabled.
6-7	Not used	Do not change these settings.

System Switch 0B		
No	FUNCTION	COMMENTS
0	Automatic reset timer Bit 1 Bit 0 Timer setting	(1, 1): Automatic reset is disabled. (Other): The machine returns to standby mode when the timer expires after the last operation.
1	0 0 1 minute 0 1 3 minutes 1 0 5 minutes 1 1 No limit	
2	Power Saver mode timer Bit 3 Bit 2 Time Limit	
3	0 0 1 minute 0 1 3 minutes 1 0 5 minutes 1 1 No limit	
4-7	Not used	Do not change these settings.

System Switch 0C - Not used (do not change any of these settings)
System Switch 0D - Not used (do not change any of these settings)
System Switch 0E - Not used (do not change any of these settings)

System Switch 0F		
No	FUNCTION	COMMENTS
0 to 7	Country code for functional settings (Hex) 00: France 10: Not used 01: Germany 11: USA 02: UK 12: Asia 03: Italy 13: Japan 04: Austria 14: Hong Kong 05: Belgium 15: South Africa 06: Denmark 16: Australia 07: Finland 17: New Zealand 08: Ireland 18: Singapore 09: Norway 19: Malaysia 0A: Sweden 1A: China 0B: Switz. 1B: Taiwan 0C: Portugal 20: Not used 0D: Holland 21: Greece 0E: Spain 0F: Israel	This country code determines the factory settings of bit switches and RAM addresses. However, it has no effect on the NCU parameter settings and communication parameter RAM addresses. Cross-reference NCU country code: Function 08, parameter CC. NOTE: If RAM reset level 1 is done, this bit switch resets to 11 (USA).

Service Tables

System Switch 10 - Not used (do not change any of these settings)
--

System Switch 11		
No	FUNCTION	COMMENTS
0-5	Not used	Do not change these settings.
6	Memory reception if no RTI or CSI received	Memory reception if there is no RTI or CSI also depends on user parameter switch 05 bit 1. This Sw U.P.05 bit 1 X 0 : Possible 0 1 : Impossible 1 1 : Only possible when the printer mechanism has no problem
7	Not used	Do not change this setting.

System Switch 12		
No	FUNCTION	COMMENTS
0 to 7	TTI printing position in the main scan direction	08 to 92 (BCD) mm. Only input even numbers. This setting determines the TTI print start position from the left edge of the paper. If the TTI is too far to the right, the file number, which is on the top right of the page, may obscure it.

System Switch 13 - Not used (do not change any of these settings)
System Switch 14 - Not used (do not change any of these settings)

System Switch 15		
No	FUNCTION	COMMENTS
0	Not used	Do not change this setting.
1	Programming with European characters 0: Disabled 1: Enabled	1: The user can program with European characters (e.g. "ä", "å") for the TTI, Quick Dial labels, etc.
2-7	Not used	Do not change these settings.

System Switch 16 - Not used (do not change any of these settings)
--

System Switch 17		
No	FUNCTION	COMMENTS
0	Not used	Do not change this setting.
1	Direct fax number entry 0: Disabled 1: Enabled	0: The user must place the original on the ADF before dialing.
2-7	Not used	Do not change these settings.

System Switch 18 - Not used (do not change any of these settings)
System Switch 19 - Not used (do not change any of these settings)
System Switch 1A - Not used (do not change any of these settings)
System Switch 1B - Not used (do not change any of these settings)
System Switch 1C - Not used (do not change any of these settings)
System Switch 1D - Not used (do not change any of these settings)
System Switch 1E - Not used (do not change any of these settings)
System Switch 1F - Not used (do not change any of these settings)

4.2.2 SCANNER SWITCHES

Scanner Switch 00																	
No	FUNCTION	COMMENTS															
0-1	Not used	Do not change these settings.															
2	Maximum transmittable document length	If the user wants to send very long documents such as well logs, select the higher setting.															
3	<table border="1"> <thead> <tr> <th>Bit 3</th> <th>2</th> <th>Setting</th> </tr> </thead> <tbody> <tr> <td>0</td> <td>0</td> <td>600 mm</td> </tr> <tr> <td>0</td> <td>1</td> <td>1200 mm</td> </tr> <tr> <td>1</td> <td>0</td> <td>Not used</td> </tr> <tr> <td>1</td> <td>1</td> <td>Not used</td> </tr> </tbody> </table>		Bit 3	2	Setting	0	0	600 mm	0	1	1200 mm	1	0	Not used	1	1	Not used
Bit 3	2		Setting														
0	0		600 mm														
0	1		1200 mm														
1	0	Not used															
1	1	Not used															
4	OR processing in immediate TX and copying (Standard resolution) 0: Disabled 1: Enabled	<p>0: The machine scans the document in 3.85 line/mm steps, then transmits or makes copies.</p> <p>1: The machine scans the document in 7.7 line/mm steps. Each pair of lines goes through OR processing before transmission or copy making. Toner may be used up earlier if OR processing is enabled.</p>															
5	OR processing in immediate TX and copying (Detail resolution) 0: Disabled 1: Enabled	<p>0: The machine scans the document in 7.7 line/mm steps, then transmits or makes copies.</p> <p>1: The machine scans the document in 15.4 line/mm steps.</p>															
6-7	Not used	Do not change these settings.															

Service Tables

Scanner Switch 01 - Not used (do not change any of these settings)
Scanner Switch 02 - Not used (do not change any of these settings)
Scanner Switch 03 - Not used (do not change any of these settings)
Scanner Switch 04 - Not used (do not change any of these settings)
Scanner Switch 05 - Not used (do not change any of these settings)
Scanner Switch 06 - Not used (do not change any of these settings)
Scanner Switch 07 - Not used (do not change any of these settings)
Scanner Switch 08 - Not used (do not change any of these settings)
Scanner Switch 09 - Not used (do not change any of these settings)
Scanner Switch 0A - Not used (do not change any of these settings)
Scanner Switch 0B - Not used (do not change any of these settings)
Scanner Switch 0C - Not used (do not change any of these settings)
Scanner Switch 0D - Not used (do not change any of these settings)
Scanner Switch 0E - Not used (do not change any of these settings)
Scanner Switch 0F - Not used (do not change any of these settings)

4.2.3 PRINTER SWITCHES

Printer Switch 00		
No	FUNCTION	COMMENTS
0	Page separation mark 0: Disabled 1: Enabled	0: No marks printed. 1: If an incoming fax requires two sheets to print, the machine prints an "x" inside a small box at the bottom right hand corner of the first sheet. Then, it prints a "2" inside a small box at the top right hand corner of the second sheet. This helps the user identify pages that have been split up.
1	Repetition of data when the received page is longer than the printer paper 0: Disabled 1: Enabled	0: The next page continues from where the previous page left off. 1: The final few mm of the previous page are printed at the top of the next page. See section 2.2.12 for details.
2-7	Not used	Do not change the settings.

Printer Switch 01		
No	FUNCTION	COMMENTS
0	Reset the fusing unit failure 0: Off 1: On (Clear)	When a fusing error occurs, set this bit to 1 after fixing the problem. The machine then resets the fusing error. Switch the machine off/on and this bit will reset itself to 0.
1-7	Not used	Do not change the settings.

Printer Switch 02 - Not used (do not change any of these settings)

Printer Switches 04 and 05			
No	FUNCTION	COMMENTS	
0	Reduction ratios used for different paper sizes (with reduction enabled in switch 03-bit 0 above)		
to	If reduction is enabled, the data will be reduced in the lengthwise direction before printing.		
7	These switches determine the maximum reduction ratio for each paper size.		
	Cross-reference		
	Page separation and data reduction: section 2.2.12.		
	Switch 04/05	US	Europe
	Bit0	Not used	A5 sideways
	Bit1	Not used	Not used
	Bit2	LT lengthwise	Not used
	Bit3	Not used	A4 lengthwise
	Bit4	Not used	F lengthwise
	Bit5	LG lengthwise	Not used
	Bit6	Not used	Not used
	Bit7	Not used	Not used
	The available paper sizes depend on the country version of the machine.		
	$\left(\frac{Sw.04}{Sw.05}\right) \cdot \begin{pmatrix} 0 \\ 0 \end{pmatrix} = 4/3, \begin{pmatrix} 1 \\ 0 \end{pmatrix} = 4/3, \begin{pmatrix} 0 \\ 1 \end{pmatrix} = 8/7, \begin{pmatrix} 1 \\ 1 \end{pmatrix} = 12/11$		

Printer Switch 06 - Not used (do not change any of these settings)
Printer Switch 07 - Not used (do not change any of these settings)
Printer Switch 08 - Not used (do not change any of these settings)
Printer Switch 09 - Not used (do not change any of these settings)
Printer Switch 0A - Not used (do not change any of these settings)
Printer Switch 0B - Not used (do not change any of these settings)
Printer Switch 0C - Not used (do not change any of these settings)
Printer Switch 0D - Not used (do not change any of these settings)
Printer Switch 0E - Not used (do not change any of these settings)
Printer Switch 0F - Not used (do not change any of these settings)

4.2.4 COMMUNICATION SWITCHES

Communication Switch 00		
No	FUNCTION	COMMENTS
0	Compression modes available in receive mode	These bits determine the compression capabilities declared in phase B (handshaking) of T.30 protocol.
1	Bit 1 0 Modes	
	0 0 MH only	
	0 1 MH/MR	
	1 0 MH/MR/MMR	
	1 1 Not used	
2	Compression modes available in transmit mode	These bits determine the compression capabilities used in the transmission and declared in phase B (handshaking) of T.30 protocol.
3	Bit 3 2 Modes	
	0 0 MH only	
	0 1 MH/MR	
	1 0 MH/MR/MMR	
	1 1 Not used	
4-7	Not used	Do not change these settings.

Communication Switch 01		
No	FUNCTION	COMMENTS
0	ECM 0: Disabled 1: Enabled	If this bit is 0, ECM is switched off for all communications.
1	Not used	Do not change this settings.
2	Wrong connection prevention method	(01) - The machine will not transmit if the last 8 digits of the received CSI do not match the last 8 digits of the dialed telephone number. This does not work for manual dialing. (10) - The same as above, except that only the last 4 digits are compared. (11) - The machine will not transmit if the other end does not identify itself with an RTI or CSI. (00) - Nothing is checked; transmission will always go ahead. Note: When enabling wrong connection prevention, disable AI short protocol.
3	Bit 3 Bit 2 Setting	
	0 0 None	
	0 1 8 digit CSI	
	1 0 4 digit CSI	
	1 1 CSI/RTI	
4	Operator call if no response is received in reply to NSF/DIS 0: Disabled 1: Enabled	Set this bit to 1 if the user expects to receive telephone calls at the same number that the machine is connected to. The machine will then alert the user if a phone call comes in.
5	Not used	Do not change the setting.
6	Maximum printable page length available	The receiving terminal informs the transmitting terminal of the setting determined by these bits in the pre-message protocol exchange (in the DIS/NSF) frames.
7	Bit 7 Bit 6 Setting	
	0 0 No limit	
	0 1 B4	
	1 0 A4	
	1 1 Not used	

Communication Switch 02											
No	FUNCTION	COMMENTS									
0	Burst error threshold 0: Low 1: High	If the received page has more consecutive error lines than the threshold, the machine sends a negative response. The low and high threshold values depend on the sub-scan resolution, and are as follows. <table border="1"> <thead> <tr> <th>Resolution</th> <th>Standard</th> <th>Detail</th> </tr> </thead> <tbody> <tr> <td>Low settings</td> <td>6</td> <td>12</td> </tr> <tr> <td>High settings</td> <td>12</td> <td>24</td> </tr> </tbody> </table> This bit is ignored if ECM is in use.	Resolution	Standard	Detail	Low settings	6	12	High settings	12	24
Resolution	Standard	Detail									
Low settings	6	12									
High settings	12	24									
1	Acceptable total error line ratio 0: 5% 1: 10%	If the error line ratio of a page exceeds the acceptable ratio, RTN will be sent to the other end. This bit is ignored if ECM is in use.									
2	Treatment of pages received with errors during G3 reception 0: Deleted from memory without printing 1: Printed	0: Pages received with errors are not printed.									
3	Hang-up decision after receiving a negative code (RTN or PIN) during G3 immediate transmission 0: No hang-up 1: Hang-up	0: Sends the next page even if RTN or PIN is received. 1: The machine will send DCN and hang up if it receives RTN or PIN. This bit is ignored for memory transmissions or if ECM is being used.									
4-7	Not used	Do not change these settings.									

Communication Switch 03		
No	FUNCTION	COMMENTS
0 to 7	Maximum number of page retransmission in a G3 memory transmission	00 - FF (Hex) times. This bit is ignored if ECM is in use.

Communication Switch 04 - Not used (do not change any of these settings)
Communication Switch 05 - Not used (do not change any of these settings)

Communication Switch 06		
No	FUNCTION	COMMENTS
0	Dialing requirements: Germany 0: Disabled 1: Enabled	This function automatically sets these switches to the required settings for each country after selecting a country code (System Switch 0F).
1	Dialing requirements: Austria 0: Disabled 1: Enabled	
2	Dialing requirements: Norway 0: Disabled 1: Enabled	

Communication Switch 06		
No	FUNCTION	COMMENTS
3	Dialing requirements: Denmark 0: Disabled 1: Enabled	This function automatically sets these switches to the required settings for each country after a country code (System Switch 0F) is programmed.
4	Dialing requirements: France 0: Disabled 1: Enabled	
5	Dialing requirements: Switzerland 0: Disabled 1: Enabled	
6-7	Not used	Do not change these settings.

Communication Switch 07 - Not used (do not change any of these settings)

Communication Switch 08 - Not used (do not change any of these settings)

Communication Switch 09 - Not used (do not change any of these settings)

Communication Switch 0A		
No	FUNCTION	COMMENTS
0	Memory transmission resumption point for redialing 0: From the error page 1: From page 1	0: The transmission begins from the page where transmission failed the previous time. 1: Transmission begins from the first page.
1-6	Not used	Do not change these settings.
7	Emergency calls using 999 0: Enabled 1: Disabled	If this bit is at 1, the machine will not allow you to dial 999 at the auto-dialer.

Service
Tables

Communication Switch 0B - Not used (do not change any of these settings)

Communication Switch 0C - Not used (do not change any of these settings)

Communication Switch 0D		
No	FUNCTION	COMMENTS
0 to 7	The available memory threshold, below which ringing detection (and therefore reception into memory) is disabled	00 to FF (Hex), unit = 2 KB (e.g. 0C(H) = 24 KB) One page is about 24 KB. The machine refers to this setting before each fax reception. If the remaining memory is below this threshold, the machine cannot receive fax messages. If this setting remains at 0, the machine will detect ringing signals and enter receive mode even if there is no available memory. This will result in communication failure.

Communication Switch 0E		
No	FUNCTION	COMMENTS
0 to 7	Minimum interval between automatic dialing attempts	06 to FF (Hex), unit = 2 s (e.g., 06(H) = 12 s) This value is the minimum time that the machine waits before it dials the next destination.

Communication Switch 0F - Not used (do not change any of these settings)

Communication Switch 10		
No	FUNCTION	COMMENTS
0 to 7	Memory transmission: Maximum number of dialing attempts to the same destination	01 - FE (Hex) times

Communication Switch 11		
No	FUNCTION	COMMENTS
0 to 7	Immediate transmission: Maximum number of dialing attempts to the same destination	01 - FE (Hex) times

Communication Switch 12		
No	FUNCTION	COMMENTS
0 to 7	Memory transmission: Interval between dialing attempts to the same destination	00 - FF (Hex) minutes

Communication Switch 13		
No	FUNCTION	COMMENTS
0 to 7	Immediate transmission: Interval between dialing attempts to the same destination	00 - FF (Hex) minutes

Communication Switch 14 - Not used (do not change any of these settings)

Communication Switch 15 - Not used (do not change any of these settings)

Communication Switch 16 - Not used (do not change any of these settings)

Communication Switch 17		
No	FUNCTION	COMMENTS
0	Not used	Do not change the settings.
1	SUB reception 0: Disabled 1: Enabled	0: Confidential reception to another maker's machine using the SUB (Sub-address) signal is disabled.
2-7	Not used	Do not change the settings.

Communication Switch 18 - Not used (do not change any of these settings)
Communication Switch 19 - Not used (do not change any of these settings)
Communication Switch 1A - Not used (do not change any of these settings)
Communication Switch 1B - Not used (do not change any of these settings)
Communication Switch 1C - Not used (do not change any of these settings)
Communication Switch 1D - Not used (do not change any of these settings)
Communication Switch 1E - Not used (do not change any of these settings)
Communication Switch 1F - Not used (do not change any of these settings)

4.2.5 G3 SWITCHES

G3 Switch 00		
No	FUNCTION	COMMENTS
0	Monitor speaker during communication (TX and RX)	(0, 0): The monitor speaker is not in use throughout communication.
1	Bit 1 Bit 0 Setting 0 0 Disabled 0 1 Up to Phase B 1 0 All the time 1 1 Not used	(0, 1): The monitor speaker is on up to phase B in the T.30 protocol. (1, 0): Used for testing. The monitor speaker is on throughout communication. Make sure that you reset these bits after testing.
2	Monitor speaker during memory transmission 0: Disabled 1: Enabled	1: The monitor speaker is in use during memory transmission.
3-6	Not used	Do not change these settings.
7	Back to back test 0: Disabled 1: Enabled	Set this bit to 1 when you wish to do a back to back test. 115 V model: Be sure to connect jumpers JP5 and JP6 on the NCU and remove BR1 before doing the test. 220 V model: Be sure to apply DC voltage between wires L1 and L2 on the NCU.

G3 Switch 01		
No	FUNCTION	COMMENTS
0-3	Not used	Do not change these settings.
4	DIS frame length 0: No limit 1: 4 bytes	1: Only the first 4 bytes in the DIS frame will transmit (set to 1 if there are communication problems with PC-based faxes, which cannot receive extended DIS frames).
5	Not used	Do not change this setting.
6	CED/ANSam emission 0: Enabled 1: Disabled	Do not change these settings, unless the any communication problem is caused by the CED/ANSam (V.34) transmission.
7	Not used	Do not change this setting.

G3 Switch 02		
No	FUNCTION	COMMENTS
0	G3 protocol mode used 0: Standard and non-standard 1: Standard only	1: Disables NSF/NSS signals (these are in non-standard mode communication).
1-4	Not used	Do not change these settings.
5	Use of modem rate history when dialing using Quick/Speed dials 0: Disabled 1: Enabled	0: Communications using Quick/Speed dials always start with the highest modem rate. 1: The machine uses the modem rate history for communications with the same machine when determining the most suitable rate for the current communication.

G3 Switch 02		
No	FUNCTION	COMMENTS
6	AI short protocol (transmission and reception) 0: Disabled 1: Enabled	Refer to Appendix B in the Group 3 Facsimile Manual for details about AI Short Protocol.
7	Not used	Do not change this setting.

G3 Switch 03		
No	FUNCTION	COMMENTS
0	DIS detection number (Echo countermeasure) 0: 1 1: 2	0: The machine will hang up if it receives the same DIS frame twice. 1: Before sending DCS, the machine waits for the second DIS, caused by echo on the line.
1	Not used	Do not change this setting.
2	V.8 protocol 0: Disabled 1: Enabled	0: V.8/V.34 communications will not be possible. Note: Do not change this setting unless the line condition is so poor the data rate slows to 14.4 kbps or lower.
3	ECM frame size 0: 256 bytes 1: 64 bytes	1: The machine transmits with a frame size of 64 bytes. Set this bit to 1 when the other terminal only has a 64 byte frame size.
4	CTC transmission conditions 0: Ricoh mode (PPR x 1) 1: ITU-T mode (PPR x 4)	When using ECM, the machine will choose a slower modem rate after receiving PPR once (Ricoth mode) or four times (ITU-T mode). This bit is ineffective in V.34 communications.
5	Modem rate for the next page after receiving a negative code (RTN or PIN) 0: No change 1: Fallback	1: The TX modem rate of the machine will fall back before sending the next page if it receives a negative code. This bit is ignored if ECM is in use.
6	Not used	Do not change this setting.
7	Polarity change after DIS/NSF detection 0: Disabled 1: Enabled	This bit should be set to "1" only to deal with communication problems caused by certain types of exchanger.

G3 Switch 04		
	FUNCTION	COMMENTS
0 to 3	Training error detection threshold	0 - F (Hex): 0 - 15 bits If the number of error bits in the received TCF is below this threshold, the machine informs the sender that the training was successful.
4-7	Not used	Do not change these settings.

G3 Switch 05		
	FUNCTION	COMMENTS
0 to 3	Initial TX modem rate Bit 3 2 1 0 Setting (BPS) 0 0 0 1 2.4 k 0 0 1 0 4.8 k 0 0 1 1 7.2 k 0 1 0 0 9.6 k 0 1 0 1 12.0 k 0 1 1 0 14.4 k 0 1 1 1 16.8 k 1 0 0 0 19.2 k 1 0 0 1 21.6 k 1 0 1 0 24.0 k 1 0 1 1 26.8 k 1 1 0 0 28.8 k 1 1 0 1 31.2 k 1 1 1 0 33.6 k Other settings - Not used	These bits set the initial starting modem rate for transmission. Use the dedicated transmission parameters if you need to change this for specific receivers.
4 to 5	Initial modem type for 9.6 k or 7.2 KBPS Bit 5 Bit 4 Setting 0 0 V.29 0 1 V.17 1 0 Not used 1 1 Not used	These bits set the initial modem type for 9.6 k and 7.2 kbps, if the initial modem rate is set at these speeds.
6-7	Not used	Do not change these settings.

G3 Switch 06		
	FUNCTION	COMMENTS
0 to 3	Initial RX modem rate Bit 3 2 1 0 Setting (BPS) 0 0 0 1 2.4 k 0 0 1 0 4.8 k 0 0 1 1 7.2 k 0 1 0 0 9.6 k 0 1 0 1 12.0k 0 1 1 0 14.4k 0 1 1 1 16.8 k 1 0 0 0 19.2 k 1 0 0 1 21.6 k 1 0 1 0 24.0 k 1 0 1 1 26.8 k 1 1 0 0 28.8 k 1 1 0 1 31.2 k 1 1 1 0 33.6 k Other settings - Not used	The settings of these bits inform the transmitting terminal of the available modem rate for the receiving machine. Use a lower setting if high speeds pose problems during reception.

G3 Switch 06		
	FUNCTION	COMMENTS
4 to 7	Modem types available for reception Bit 7 6 5 4 Setting 0 0 0 1 V.27ter 0 0 1 0 V.27ter, V.29 0 0 1 1 V.27ter, V.29, V.33 0 1 0 0 V.27ter, V.29, V33, V17 0 1 0 1 V.27ter, V.29, V.33, V.17, V.34 Other settings - Not used	The settings of these bits inform the transmitting terminal of the available modem type for the receiving machine. V.33 is an exclusive Ricoh mode (NSF).

G3 Switch 07		
	FUNCTION	COMMENTS
0 1	PSTN cable equalizer (TX mode) Bit 1 Bit 0 Setting 0 0 None 0 1 Low 1 0 Medium 1 1 High	Use a higher setting if there is signal loss at higher frequencies because of the length of wire between the modem and the telephone exchange. Use the dedicated transmission parameters if you need to change this for specific receivers. Also, try using the cable equalizer if one or more of the following symptoms occurs: <ul style="list-style-type: none"> • Communication error • Modem rate fallback occurs frequently. Note: This setting is ineffective in V.34 communications.
2 3	PSTN cable equalizer (RX mode) Bit 3 Bit 2 Setting 0 0 None 0 1 Low 1 0 Medium 1 1 High	Use a higher setting if there is signal loss at higher frequencies because of the length of wire between the modem and the telephone exchange. Also, try using the cable equalizer if one or more of the following symptoms occurs: <ul style="list-style-type: none"> • Communication error with error codes such as 0-20, 0-23, etc. • Modem rate fallback occurs frequently. Note: This setting is ineffective in V.34 communications.
4	PSTN external cable equalizer (V.27ter, V.29, V.33/V.17, V.8 rx mode) 0: Disabled 1: Enabled	Keep this bit at "1" in most cases.
5	PSTN external cable equalizer (V.34 rx mode) 0: Disabled 1: Enabled	Set this bit to 0 when the line quality is good. (e.g. digital PABX) The V.34 modem rate may decrease from equalizer over correction.
6-7	Not used	Do not change these settings.

Service Tables

G3 Switch 08				
	FUNCTION			COMMENTS
0	PABX cable equalizer (TX mode)			Use a higher setting if there is signal loss at higher frequencies because of the length of wire between the modem and the telephone exchange. Use the dedicated transmission parameters if you need to change this for specific receivers. Also, try using the cable equalizer if one or more of the following symptoms occurs: <ul style="list-style-type: none"> • Communication error • Modem rate fallback occurs frequently. Note: This setting is ineffective in V.34 communications.
1	Bit 1	Bit 0	Setting	
	0	0	None	
	0	1	Low	
	1	1	High	
2	PABX cable equalizer (RX mode)			Use a higher setting if there is signal loss at higher frequencies because of the length of wire between the modem and the telephone exchange. Also, try using the cable equalizer if one or more of the following symptoms occurs: <ul style="list-style-type: none"> • Communication error with error codes such as 0-20, 0-23, etc. • Modem rate fallback occurs frequently. Note: This setting is ineffective in V.34 communications.
3	Bit 3	Bit 2	Setting	
	0	0	None	
	0	1	Low	
	1	1	High	
4	PSTN external cable equalizer (V.27ter, V.29, V.33/V.17, V.8 rx mode) 0: Disabled 1: Enabled			Set this bit to 0 when line quality is good. (e.g. digital PABX)
5	PSTN external cable equalizer (V.34 rx mode) 0: Disabled 1: Enabled			Set this bit to 0 when line quality is good. (e.g. digital PABX) The V.34 modem rate may decrease from equalizer over correction.
6-7	Not used			Do not change these settings.

G3 Switch 09 - Not used (do not change these settings)

G3 Switch 0A		
	FUNCTION	COMMENTS
0	Maximum allowable carrier drop during image data reception	These bits set the acceptable modem carrier drop time. Try using a longer setting if error code 0-22 is frequent.
1	Bit 1 Bit 0 Value (ms)	
	0 0 200	
	0 1 400	
	1 0 800	
	1 1 Not used	
2-3	Not used	Do not change these settings.
4	Maximum allowable frame interval during image data reception. 0: 5 s 1: 13 s	This bit determines the maximum interval between each EOL signal (end-of-line) or between each ECM frame from the other end. Try using a longer setting if error code 0-21 is frequent.
5	Not used	Do not change this setting.
6	Reconstruction time for the first line in receive mode 0: 6 s 1: 12 s	When a computer controls the sending terminal, there may be a delay in receiving page data after the local machine accepts set-up data and sends CFR. If this occurs, set this bit to 1 to give the sending machine more time to send data. Refer to error code 0-20.
7	Not used	Do not change this setting.

Service Tables

G3 Switch 0B		
	FUNCTION	COMMENTS
0	Protocol requirements: Europe 0: Disabled 1: Enabled	Program these bit switches manually to match local requirements.
1	Protocol requirements: Spain 0: Disabled 1: Enabled	
2	Protocol requirements: Germany 0: Disabled 1: Enabled	
3	Protocol requirements: France 0: Disabled 1: Enabled	
4	PTT requirements: Germany 0: Disabled 1: Enabled	
5-7	Not used	Do not change these settings.

G3 Switch 0C		
	FUNCTION	COMMENTS
0	Pulse dialing method	P = Number of pulses sent out, N = Number dialed.
	Bit 1 Bit 0 Setting	
1	0 0 Normal (P=N)	
	0 1 Oslo (P=10 - N)	
	1 0 Sweden (N+1)	
	1 1 Not used	
2	Not used	Do not change these settings.
3	Ring detection method 0: Ringing 1: CNG (Germany only)	0: The machine starts to look for CNG as soon as it detects off hook in auto reception mode. 1: The machine starts to look for CNG as soon as it detects ringing in auto reception mode. Note: This bit should be set to "1" only in Germany.
4-7	Not used	Do not change these settings.

G3 Switch 0D - Not used (do not change these settings)
G3 Switch 0E - Not used (do not change these settings)
G3 Switch 0F - Not used (do not change these settings)

4.3 NCU PARAMETERS

The following tables give the RAM addresses and the parameter calculation units that the machine uses for ringing signal detection and automatic dialing. The factory settings for each country are also given. The RAM read/write (Function 06) must change most of these, but NCU Parameter programming (Function 08) can change some others; if Function 08 is in use, the Remarks column indicates it. The RAM is in hex code unless (BCD) is included in the Unit column.

Address	Function	Unit	Remarks																																																																																				
807F00	Country code for NCU parameters	Use the Hex value to program the country code directly into this address, or use the decimal value to program it using Function 08 (parameter C.C.). <table border="1"> <thead> <tr> <th>Country</th> <th>Decimal</th> <th>Hex</th> </tr> </thead> <tbody> <tr><td>France</td><td>00</td><td>00</td></tr> <tr><td>Germany</td><td>01</td><td>01</td></tr> <tr><td>UK</td><td>02</td><td>02</td></tr> <tr><td>Italy</td><td>03</td><td>03</td></tr> <tr><td>Austria</td><td>04</td><td>04</td></tr> <tr><td>Belgium</td><td>05</td><td>05</td></tr> <tr><td>Denmark</td><td>06</td><td>06</td></tr> <tr><td>Finland</td><td>07</td><td>07</td></tr> <tr><td>Ireland</td><td>08</td><td>08</td></tr> <tr><td>Norway</td><td>09</td><td>09</td></tr> <tr><td>Sweden</td><td>10</td><td>0A</td></tr> <tr><td>Switzerland</td><td>11</td><td>0B</td></tr> <tr><td>Portugal</td><td>12</td><td>0C</td></tr> <tr><td>Holland</td><td>13</td><td>0D</td></tr> <tr><td>Spain</td><td>14</td><td>0E</td></tr> <tr><td>Israel</td><td>15</td><td>0F</td></tr> <tr><td>USA</td><td>17</td><td>11</td></tr> <tr><td>Asia</td><td>18</td><td>12</td></tr> <tr><td>Hong Kong</td><td>20</td><td>14</td></tr> <tr><td>South Africa</td><td>21</td><td>15</td></tr> <tr><td>Australia</td><td>22</td><td>16</td></tr> <tr><td>New Zealand</td><td>23</td><td>17</td></tr> <tr><td>Singapore</td><td>24</td><td>18</td></tr> <tr><td>Malaysia</td><td>25</td><td>19</td></tr> <tr><td>China</td><td>26</td><td>1A</td></tr> <tr><td>Taiwan</td><td>27</td><td>1B</td></tr> <tr><td>Greek</td><td>33</td><td>21</td></tr> </tbody> </table>		Country	Decimal	Hex	France	00	00	Germany	01	01	UK	02	02	Italy	03	03	Austria	04	04	Belgium	05	05	Denmark	06	06	Finland	07	07	Ireland	08	08	Norway	09	09	Sweden	10	0A	Switzerland	11	0B	Portugal	12	0C	Holland	13	0D	Spain	14	0E	Israel	15	0F	USA	17	11	Asia	18	12	Hong Kong	20	14	South Africa	21	15	Australia	22	16	New Zealand	23	17	Singapore	24	18	Malaysia	25	19	China	26	1A	Taiwan	27	1B	Greek	33	21
Country	Decimal	Hex																																																																																					
France	00	00																																																																																					
Germany	01	01																																																																																					
UK	02	02																																																																																					
Italy	03	03																																																																																					
Austria	04	04																																																																																					
Belgium	05	05																																																																																					
Denmark	06	06																																																																																					
Finland	07	07																																																																																					
Ireland	08	08																																																																																					
Norway	09	09																																																																																					
Sweden	10	0A																																																																																					
Switzerland	11	0B																																																																																					
Portugal	12	0C																																																																																					
Holland	13	0D																																																																																					
Spain	14	0E																																																																																					
Israel	15	0F																																																																																					
USA	17	11																																																																																					
Asia	18	12																																																																																					
Hong Kong	20	14																																																																																					
South Africa	21	15																																																																																					
Australia	22	16																																																																																					
New Zealand	23	17																																																																																					
Singapore	24	18																																																																																					
Malaysia	25	19																																																																																					
China	26	1A																																																																																					
Taiwan	27	1B																																																																																					
Greek	33	21																																																																																					
807F01	Line current detection time	20 ms	Line current is not detected if 807F01 contains FF.																																																																																				
807F02	Line current wait time																																																																																						
807F03	Line current drop detect time																																																																																						

Service Tables

Address	Function	Unit	Remarks
807F04	PSTN dial tone frequency upper limit (high byte)	Hz (BCD)	If both addresses contain FF(H), tone detection is disabled.
807F05	PSTN dial tone frequency upper limit (low byte)		
807F06	PSTN dial tone frequency lower limit (high byte)	Hz (BCD)	If both addresses contain FF(H), tone detection is disabled.
807F07	PSTN dial tone frequency lower limit (low byte)		
807F08	PSTN dial tone detection time	20 ms	If 807F08 contains FF(H), the machine pauses for the pause time (address 807F0D / 807F0E). See Note 3 (Italy).
807F09	PSTN dial tone reset time (low)		
807F0A	PSTN dial tone reset time (high)		
807F0B	PSTN dial tone continuous tone time		
807F0C	PSTN dial tone permissible drop time		
807F0D	PSTN wait interval (low)		
807F0E	PSTN wait interval (high)		
807F0F	PSTN ring-back tone detection time	20 ms	Detection is disabled if this contains FF(H).
807F10	PSTN ring-back tone off detection time	20 ms	
807F11	PSTN detection time for the silent period after ring-back tone detected (low)	20 ms	
807F12	PSTN detection time for the silent period after ring-back tone detected (high)	20 ms	
807F13	PSTN busy tone frequency upper limit (high byte)	Hz (BCD)	If both addresses contain FF(H), tone detection is disabled.
807F14	PSTN busy tone frequency upper limit (low byte)		
807F15	PSTN busy tone frequency lower limit (high byte)	Hz (BCD)	If both addresses contain FF(H), tone detection is disabled.
807F16	PSTN busy tone frequency lower limit (low byte)		
807F17	PABX dial tone frequency range (high byte)	Hz (BCD)	If both addresses contain FF(H), tone detection is disabled.
807F18	PABX dial tone frequency range (low byte)		
807F19	PABX dial tone frequency lower limit (high byte)	Hz (BCD)	If both addresses contain FF(H), tone detection is disabled.
807F1A	PABX dial tone frequency lower limit (low byte)		

Address	Function	Unit	Remarks
807F1B	PABX dial tone detection time	20 ms	If 807F1B contains FF, the machine pauses for the pause time (807F20 / 807F21).
807F1C	PABX dial tone reset time (low)		
807F1D	PABX dial tone reset time (high)		
807F1E	PABX dial tone continuous tone time		
807F1F	PABX dial tone permissible drop time		
807F20	PABX wait interval (high)		
807F21	PABX wait interval (low)		
807F22	PABX ring-back tone detection time	20 ms	If both addresses contain FF(H), tone detection is disabled.
807F23	PABX ring-back tone off detection time	20 ms	
807F24	PABX detection time for the silent period after ring-back tone detected (low)	20 ms	If both addresses contain FF(H), tone detection is disabled.
807F25	PABX detection time for the silent period after ring-back tone detected (high)	20 ms	If both addresses contain FF(H), tone detection is disabled.
807F26	PABX busy tone frequency upper (high byte)	Hz (BCD)	If both addresses contain FF(H), tone detection is disabled.
807F27	PABX busy tone frequency lower (low byte)		
807F28	PABX busy tone frequency lower (high byte)	Hz (BCD)	If both addresses contain FF(H), tone detection is disabled.
807F29	PABX busy tone frequency lower (low byte)		
807F2A	Busy tone ON time: range 1	20 ms	
807F2B	Busy tone OFF time: range 1		
807F2C	Busy tone ON time: range 2		
807F2D	Busy tone OFF time: range 2		
807F2E	Busy tone ON time: range 3		
807F2F	Busy tone OFF time: range 3		
807F30	Busy tone ON time: range 4		
807F31	Busy tone OFF time: range 4		
807F32	Busy tone-continuous tone detection time		

Service Tables

Address	Function	Unit	Remarks																									
807F33	<p>Busy tone signal state time tolerance for all ranges, and number of cycles required for detection (a setting of 4 cycles means that ON-OFF-ON or OFF-ON-OFF must be detected twice).</p> <p>Tolerance (\pm)</p> <table border="0"> <tr> <td>Bit</td> <td>1</td> <td>0</td> <td></td> <td></td> </tr> <tr> <td></td> <td>0</td> <td>0</td> <td>75%</td> <td>Bits 2 and 3 must always be kept at 0.</td> </tr> <tr> <td></td> <td>0</td> <td>1</td> <td>50%</td> <td></td> </tr> <tr> <td></td> <td>1</td> <td>0</td> <td>25%</td> <td></td> </tr> <tr> <td></td> <td>1</td> <td>1</td> <td>12.5%</td> <td></td> </tr> </table> <p>Bits 7, 6, 5, 4 - number of cycles required for cadence detection</p>	Bit	1	0				0	0	75%	Bits 2 and 3 must always be kept at 0.		0	1	50%			1	0	25%			1	1	12.5%			
Bit	1	0																										
	0	0	75%	Bits 2 and 3 must always be kept at 0.																								
	0	1	50%																									
	1	0	25%																									
	1	1	12.5%																									
807F34	International dial tone frequency upper limit (high byte)	Hz (BCD)	If both addresses contain FF(H), tone detection is disabled.																									
807F35	International dial tone frequency upper limit (low byte)																											
807F36	International dial tone frequency lower limit (high byte)	Hz (BCD)	If both addresses contain FF(H), tone detection is disabled.																									
807F37	International dial tone frequency lower limit (low byte)																											
807F38	International dial tone detection time	20 ms	<p>If 807F38 contains FF, the machine pauses for the pause time (807F3D / 807F3E).</p> <p>See Note 3 (Belgium).</p>																									
807F39	International dial tone reset time (low)																											
807F3A	International dial tone reset time (high)																											
807F3B	International dial tone continuous tone time																											
807F3C	International dial tone permissible drop time																											
807F3D	International dial wait interval (low)																											
807F3E	International dial wait interval (high)																											
807F3F	Country dial tone upper frequency limit (high)	Hz (BCD)	If both addresses contain FF(H), tone detection is disabled.																									
807F40	Country dial tone upper frequency limit (low)																											
807F41	Country dial tone lower frequency limit (high)																											
807F42	Country dial tone lower frequency limit (low)																											
807F43	Country dial tone detection time	20 ms	<p>If 807F43 contains FF, the machine pauses for the pause time (807F48 / 807F49).</p>																									
807F44	Country dial tone reset time (low)																											
807F45	Country dial tone reset time (high)																											
807F46	Country dial tone continuous tone time																											
807F47	Country dial tone permissible drop time																											
807F48	Country dial wait interval (low)																											

Address	Function	Unit	Remarks
807F49	Country dial wait interval (high)	20 ms	
807F4A	Time between opening or closing the Ds relay and opening the Di relay	1 ms	See Notes 4 and 7. Function 08 (parameter 11).
807F4B	Break time for pulse dialing	1 ms	See Note 4. Function 08 (parameter 12).
807F4C	Make time for pulse dialing	1 ms	See Note 4. Function 08 (parameter 13).
807F4D	Time between final Di relay closure and Ds relay opening or closing	1 ms	See Notes 4 and 7. Function 08 (parameter 14).
807F4E	Minimum pause between dialed digits (pulse dial mode)	20 ms	See Note 4. Function 08 (parameter 15).
807F4F	Time waited when a pause is entered at the operation panel		Function 08 (parameter 16). See Note 4.
807F50	DTMF tone on time	1 ms	Function 08 (parameter 17).
807F51	DTMF tone off time		Function 08 (parameter 18).
807F52	Tone attenuation level of DTMF signals while dialing (high frequency group)	-dBm x 0.5	Function 08 (parameter 19). See Note 6.
807F53	Tone attenuation value difference between high frequency tone and low frequency tone in DTMF signals	-Nx0.5 (dB)	Function 08 (parameter 20). See Note 6.
807F54	PSTN: DTMF tone attenuation level after dialing (high frequency group)	-dBm x 0.5	Function 08 (parameter 21). See Note 6.
807F55 to 807F58	Not used		Do not change these settings.
807F59	Grounding time (ground start mode)	20 ms	The Gs relay remains closed for this interval.
807F5A	Break time (flash start mode)	1 ms	The OHDI relay is open for this interval.
807F5B 807F5C	International dial access code	BCD	For a code of 100: 807F5B - F1 807F5C - 00
807F5D	PSTN access pause time	20 ms	It waits this amount of time for each pause input after the PSTN access code. Up to 7 of these can be input. If this address contains FF[H], the pause time stored in address 807F4F is used.

Address	Function	Unit	Remarks
807F5E	Progress tone detection level, and cadence detection enable flags	Bit 7 Bit 6 Bit 5 0 0 0 0 0 1 0 1 0 1 0 0 1 1 0	dBm -25.0 -35.0 -30.0 -40.0 -49.0
		Bits 2, 0 - See Note 3.	
807F5F to 807F64	Not used		Do not change these settings.
807F65	Inter-city dial prefix (high)	BCD	For a code of 0: 807F65 - FF 807F66 - F0
807F66	Inter-city dial prefix (low)	BCD	
807F67 to 807F68	Not used		Do not change these settings.
807F69	Distinctive ring	Hex	00(H): OFF, 01(H): ON
807F6A	Distinctive ring minimum off time	1ms	
807F6B	Distinctive ring maximum one cycle time	20 ms ± 20 ms	
807F72	Acceptable ringing signal frequency: range 1, upper limit	1000/ N (Hz)	Function 08 (parameter 02).
807F73	Acceptable ringing signal frequency: range 1, lower limit		Function 08 (parameter 03).
807F74	Acceptable ringing signal frequency: range 2, upper limit		Function 08 (parameter 04).
807F75	Acceptable ringing signal frequency: range 2, lower limit		Function 08 (parameter 05).
807F76	Number or rings until a call is detected	1	Function 08 (parameter 06).
807F77	Minimum required length of the first ring	20 ms	See Note 5. Function 09 (parameter 07).
807F78	Minimum required length of the second and subsequent rings	20 ms	Function 08 (parameter 08).
807F79	Ringing signal detection reset time (low)	20 ms	Function 08 (parameter 09).
807F7A	Ringing signal detection reset time (high)		Function 08 (parameter 10).
807F7B to 807F80	Not used		Do not change these settings.
807F81	Interval between dialing the last digit and switching the Oh relay over to the external telephone when dialing from the operation panel in handset mode.	20 ms	Factory setting: 500 ms

Address	Function	Unit	Remarks
807F82	Bits 0 and 1 - Handset off-hook detection time Bit 1 0 Setting 0 0 200 ms 0 1 800 ms Other Not used Bits 2 and 3 - Handset on-hook detection time Bit 3 2 Setting 0 0 200 ms 0 1 800 ms Other Not used Bits 4 to 7 - Not used		
807FA1	Acceptable CED detection frequency upper limit (high byte)	BCD (Hz)	If both addresses contain FF(H), tone detection is disabled.
807FA2	Acceptable CED detection upper frequency upper limit (low byte)		
807FA3	Acceptable CED detection frequency lower limit (high byte)	BCD (Hz)	If both addresses contain FF(H), tone detection is disabled.
807FA4	Acceptable CED detection upper frequency lower limit (low byte)		
807FA5	CED detection time	20 ms ± 20 ms	Factory setting: 200 ms
807FA6	Acceptable CNG detection frequency upper limit (high byte)	BCD (Hz)	If both addresses contain FF(H), tone detection is disabled.
807FA7	Acceptable CNG detection upper frequency upper limit (low byte)		
807FA8	Acceptable CNG detection frequency lower limit (high byte)	BCD (Hz)	If both addresses contain FF(H), tone detection is disabled.
807FA9	Acceptable CNG detection upper frequency lower limit (low byte)		
807FAA	Not used		Do not change these settings.
807FAB	CNG on time	20 ms	Factory setting: 500 ms
807FAC	CNG off time	20 ms	Factory setting: 200 ms
807FAD	Number of CNG cycles required for detection		The data is coded in the same way as address 807F33. Factory setting: 23(H)
807FAE	Not used		Do not change this setting.
807FAF	Acceptable AI short protocol tone (800Hz) detection frequency upper limit (high byte)	BCD (Hz)	If both addresses contain FF(H), tone detection is disabled.
807FB0	Acceptable AI short protocol tone (800Hz) detection upper frequency upper limit (low byte)		

Service Tables

Address	Function	Unit	Remarks
807FB1	Acceptable AI short protocol tone (800Hz) detection frequency lower limit (high byte)	BCD (Hz)	If both addresses contain FF(H), tone detection is disabled.
807FB2	Acceptable AI short protocol tone (800Hz) detection upper frequency lower limit (low byte)		
807FB3	Detection time for 800 Hz AI short protocol tone	20 ms	Factory setting: 360 ms
807FB4	PSTN: Tx level from the modem	- dBm	Function 08 (parameter 01).
807FB5	PSTN: 1100 Hz tone transmission level	- N 807FB4 - 0.5N 807FB5 (dB)	
807FB6	PSTN: 2100 Hz tone transmission level	- N 807FB4 - 0.5N 807FB6 (dB)	
807FB7	PABX: Tx level from the modem	- dBm	
807FB8	PABX: 1100 Hz tone transmission level	- N 807FB7 - 0.5N 807FB8 (dB)	
807FB9	PABX: 2100 Hz tone transmission level	- N 807FB7 - 0.5N 807FB9 (dB)	
807FBA to 807FBC	Not used		Do not change these settings.
807FBD	Modem turn-on level (incoming signal detection level)	-37-0.5N (dBm)	
807FDA	T.30 T1 timer	1 s	
807FE0 bit 3	Maximum wait time for post message	0: 12 s 1: 30 s	1: Maximum wait time for post message (EOP/EOM/MPS) can be changed to 30 s. Change this bit to "1" if communication errors occur frequently during V.17 reception.



NOTES

1. If a setting is unnecessary, store FF in the address.
2. In, Europe, if the country code is not specified, set it to UK (02).
3. Italy and Belgium only
RAM address 807F5E: the lower four bits have the following meaning.
Bit 2 1: International dial tone cadence detection enabled (Belgium)
Bit 1 Not used
Bit 0 1: PSTN dial tone cadence detection enabled (Italy)

If bit 0 or bit 2 is set to 1, the functions of the following RAM addresses change.
807F08 (if bit 0 = 1) or 807F38 (if bit 2 = 1): tolerance for on or off state duration (%), and number of cycles required for detection, coded as in address 807F33.
807F0B (if bit 0 = 1) or 807F3B (if bit 2 = 1): on time, hex code (unit = 20 ms)
807F0C (if bit 0 = 1) or 807F3C (if bit 2 = 1): off time, hex code (unit = 20 ms)
4. Pulse dial parameters (addresses 807F4A to 807F4F) are the values for 10 PPS. If 20 PPS is used, the machine automatically compensates.
5. The first ring may remain undetected until 1 to 2.5 wavelengths after the time specified by this parameter.
6. The calculated level must be between 0 and 10.
The attenuation levels calculated from RAM data are:
High frequency tone: $- 0.5 \times N_{807F52/807F54}$ dBm
Low frequency tone: $- 0.5 \times (N_{807F52/807F54} + N_{807F53})$ dBm
Note: N_{807F52} , for example, means the value stored in address 807F52(H)
7. 807F4A: Europe - Between Ds opening and Di opening, France - Between Ds closing and Di opening
807F4D: Europe - Between Ds closing and Di closing, France - Between Ds opening and Di closing

4.4 DEDICATED TRANSMISSION PARAMETERS







Each Quick Dial Key and Speed Dial Code has four bytes of programmable parameters allocated to it. If transmissions to a particular machine often experience problems, store that terminal's fax number as a Quick Dial or Speed Dial, and adjust the parameters allocated to that number.

The programming procedure will be explained first. Then, the four bytes will be described.





4.4.1 PROGRAMMING PROCEDURE

1. Set bit 3 of System Bit Switch 04 to 1.
2. Either use Function 31 (for a Quick Dial number) or Function 32 (for a Speed Dial number)

Example: Change the Parameters in Quick Dial 10.

3.    
4. Press the Quick Dial key 10.
Note: When selecting Speed Dial 10 with Function 32, press   on the ten keypad.
5. Press  four times.
6. The settings for byte 0 are now displayed. Press a number from 0 to 7 corresponding to the bit that you wish to change.

Example: Change bit 7 to 1: Press 7

7. To scroll through the parameter bytes, either:
Select the next byte: 
or
Select the previous byte: 
until the correct byte is displayed. Then go back to step 6.
8. After the setting is changed, press .
9. To finish, press .
10. After finishing, reset bit 3 of System Bit Switch 04 to 0.

4.4.2 PARAMETERS

The initial settings of the following parameters are all FF(H) - all the parameters are disabled.



Byte 0	
FUNCTION AND COMMENTS	
<p>ITU-T T1 time If the connection time to a particular terminal is longer than the NCU parameter setting, adjust this byte. The T1 time is the value stored in this byte (in hex code), multiplied by 1 second. Range:1 to 127 s (01h to 7Fh) 00h or FFh - The local NCU parameter factory setting is used. Do not program a value between 80h and FEh.</p>	

Byte 1		
	FUNCTION	COMMENTS
0 to 3	TX level Bit 3 2 1 0 Setting (dBm) 0 0 0 0 0 0 0 0 1 -1 : 1 1 1 1 -15	If communication with a particular remote terminal often contains errors, the signal level may be inappropriate. Adjust the TX level for communications with that terminal until the results are better.
4	TX level setting 0: Enabled 1: Disabled (bits 0 to 4 must all be at 1 to disable)	0: When enabling the TX level setting, change this bit to 0, then change the settings of bits 0 through 3 above. 1: When disabling the TX level setting, change all of the bits 0 through 4 to 1.
5 to 6	Cable equalizer Bit 6 Bit 5 Setting 0 0 None 0 1 Low 1 0 Medium 1 1 High	Use a higher setting if there is signal loss at higher frequencies because of the length of wire between the modem and the telephone exchange when calling the number stored in this Quick/Speed Dial. Also, try using the cable equalizer if one or more of the following symptoms occurs. <ul style="list-style-type: none"> • Communication error with error codes such as 0-20, 0-23, etc. • Modem rate fallback occurs frequently.
7	Cable equalizer setting 0: Enabled 1: Disabled (bits 5 to 7 must all be at 1 to disable)	0: When enabling the cable equalizer setting, change this bit to 0, then change the settings of bits 5 and 6 above. 1: When disabling the cable equalizer setting, change all of the bits 5, 6 and 7 to 1.

Service Tables

Byte 2		FUNCTION	COMMENTS			
0 to 3	Initial TX modem rate		If training with a particular remote terminal always takes too long, the initial modem rate may be too high. Reduce the initial TX modem rate using these bits.			
	Bit 3	Bit 2		Bit 1	Bit 0	Setting (bps)
	0	0		0	0	Not used
	0	0		0	1	2,400
	0	0		1	0	4,800
	0	0		1	1	7,200
	0	1		0	0	9,600
	0	1		0	1	12 000
	0	1		1	0	14,400
		:				
		1	1	0	1	31,200
		1	1	1	0	33,600
		1	1	1	1	Setting disabled
4 to 7	Not used		Do not change these settings.			

Byte 3		FUNCTION	COMMENTS	
0	Not used		Do not change this setting.	
1	Not used			
2	DIS/NSF detection method		(0, 1): Use this setting if echoes on the line are interfering with the set-up protocol at the start of transmission. The machine will then wait for the second DIS or NSF before sending DCS or NSS.	
3	Bit 3	Bit 2		Setting
	0	0		First DIS or NSF
	0	1		Second DIS or NSF
	1	0	First DIS or NSF	
	1	1	Setting disabled	
4	V.8 protocol 0: Disabled 1: Enabled		If transmissions to a specific destination always end at a low modem rate (lower than 14,400 bps), disable V.8 protocol so that V.34 protocol will not be used. 0: V.34 communication will not be possible.	
5	Compression modes available in transmit mode 0: MH only 1: All available compression modes		This bit determines the capabilities that are informed to the other terminal during transmission.	
6	ECM during transmission		For example, if ECM is switched on but is not wanted when sending to a particular terminal, use the (0, 0) setting.	
7	Bit 7	Bit 6		Setting
	0	0		Disabled
	0	1		Enabled
	1	0	Disabled	
	1	1	Setting disabled	

4.5 SERVICE RAM ADDRESSES

⚠ CAUTION

Do not change settings marked as “Not used” or “Read only.”

800001 to 800004(H) - ROM version (Read only)

- 800001(H) - Revision number (BCD)
- 800002(H) - Year (BCD)
- 800003(H) - Month (BCD)
- 800004(H) - Day (BCD)

800005(H) - RAM Reset Level 1

Change the data at this address to FF (H), then switch the machine off and on to reset all the system settings.

Caution: Before using this RAM, print the settings of all the system parameters (System Parameter List).

800006 to 800016(H) - Machine's serial number (17 digits - ASCII)

800018(H) - Total program checksum (low)

800019(H) - Total program checksum (high)

80001A(H) - Boot program checksum (low)

80001B(H) - Boot program checksum (high)

80001C(H) - Main program checksum (low)

80001D(H) - Main program checksum (high)

80001E(H) - RDS program update counter (hex)

800020 to 80003F(H) - System bit switches

800040 to 80004F(H) - Scanner bit switches

800050 to 80005F(H) - Printer bit switches

800060 to 80007F(H) - Communication bit switches

800080 to 80008F(H) - G3 bit switches

8000A0(H) - User parameter switch 00

Bit 0 to 3: Not used

Bits 4 and 5: Scanning resolution home position

Bit	5	4	Setting
	0	0	Standard
	0	1	Detail
	1	0	Fine
	1	1	Halftone

Bit 6: Transmission mode home position

0: Memory TX, 1: Immediate TX

Bit 7: Not used

8000A1(H) - User parameter switch 01

Bits 0 to 6: Not used

Bit 7: Settings return to home position after transmission 0: Disabled, 1: Enabled

8000A2(H) - User parameter switch 02

Bit 0: Forwarding mark printing on forwarded messages 0: Disabled, 1: Enabled

Bit 1: Center mark printing on received copies 0: Disabled, 1: Enabled

Bit 2: Not used

Bit 3: TSI included in transmitted messages 0: Disabled, 1: Enabled

Bits 4 to 7: Not used

8000A3(H) - User parameter switch 03 (Automatic report printout)

Bit 0: Transmission result report (memory transmissions) 0: Off, 1: On

Bit 1: Not used

Bit 2: Memory storage report 0: Off, 1: On

Bit 3: Not used

Bit 4: Polling result report (polling reception) 0: Off, 1: On

Bit 5: Transmission result report (immediate transmissions) 0: Off, 1: On

Bit 6: Not used

Bit 7: Journal 0: Off, 1: On

8000A4(H) - User parameter switch 04

Bit 0: Confidential reception report 0: Off, 1: On

Bits 1 to 6: Not used

Bit 7: Includes a sample image on reports 0: Off, 1: On

8000A5(H) - User parameter switch 05

Bit 0: Substitute reception 0: Off, 1: On

Bit 1: Memory reception if no RTI or CSI received 0: Possible, 1: Impossible

Bits 2 to 5: Not used

Bit 6: Fusing lamp control during energy saver mode
0: Lamp off, 1: Standby temperature

Bit 7: Not used (keep this bit at 0.)

8000A6(H) - User parameter switch 06

Bit 0: TTI 0: Off, 1: On

Bits 1 to 3: Not used

Bit 4: Batch transmission 0: Off, 1: On

Bits 5 to 7: Not used

8000A7(H) - User parameter switch 07

Not used

8000A8(H) - User parameter switch 08

Bits 0 and 1: Not used

Bits 2 and 3: Authorized reception

Bit	3	2	Setting
	X	0	Disabled
	0	1	Faxes from senders whose RTIs/CSIs are specified for this feature are accepted.
	1	1	Faxes from senders whose RTIs/CSIs are not specified for this feature are accepted.

Bits 4 and 5: Specified cassette selection (optional cassette required)

Bit	5	4	Setting
	X	0	Disabled
	0	1	Faxes from senders whose RTIs/CSIs are specified for this feature are printed to the paper in a specified cassette.
	1	1	Faxes from senders whose RTIs/CSIs are not specified for this feature are printed to the paper in a specified cassette.

Bits 6 and 7: Forwarding (optional memory card required)

Bit	7	6	Setting
	X	0	Disabled
	0	1	Faxes from senders whose RTIs/CSIs are specified for this feature are forwarded.
	1	1	Faxes from senders whose RTIs/CSIs are not specified for this feature are forwarded.

8000A9(H) - User parameter switch 09

Not used

8000AA(H) - User parameter switch 10

Bit 0: Reverse order printing

0: Disabled, 1: Enabled

Bits 1 to 6: Not used

Bit 7: Halftone type

0: Error diffusion, 1: Dither

8000AB(H) - User parameter switch 11

Bits 0 and 1: Not used

Bit 2: Detect blank sheet

0: Disabled, 1: Enabled

Bits 3 to 5: Not used

Bit 6: Printout of messages received while acting as a forwarding station

0: Off, 1: On

Bit 7: Not used

8000AC(H) - User parameter switch 12

Bit 0: Not used

Bit 1: Distinctive ring detection (USA only)

0: Disabled, 1: Enabled

Bits 2 to 7: Not used

8000AD(H) - User parameter switch 13

Bits 0 and 1: PSTN access method from behind PABX

Bit	1	0	Setting
	0	0	PSTN
	0	1	Loop start
	1	0	Ground start (Europe & Asia model only, excluding France models)
	1	1	Flash start (Europe & Asia model only)

Bits 2 to 7: Not used

8000B9(H) - User function 62 settings

Bit 0: Night timer 0: Disabled, 1: Enabled

Bits 1 to 3: Not used

Bit 4: RDS operation 0: Not acceptable
1: Acceptable for the limit specified by system switch 03

Bits 5 and 6: Not used

Bit 7: Daylight saving time 0: Disabled, 1: Enabled

8000BA(H) - User function 62 setting

Bit 0: Not used

Bit 1: Dialing type 0: Pulse dialing (10 PPS), 1: Tone (DTMF) dialing

Bits 2 to 7: Not used

8000BB(H) - PSTN access number for loop start

Access number Hex value to program (BCD)

0	F0
↓	↓
0	F0
00	00
↓	↓
99	99

8000BC(H) - User function 61 setting

Bits 0 to 7: The number of rings when auto mode is selected 0-99 (BCD)

8000BF(H) - User function 62 setting

Bit 0 to 7: Not used, do not change the setting.

8000C8 to 8000DB(H) - RTI (Max. 20 characters - ASCII) - Note 1**8000DC to 8000EF(H) - CSI (Max. 20 characters - ASCII)****8000F0 to 80010F(H) - TTI (Max. 32 characters - ASCII) - Note 1****800110(H) - Number of CSI characters (Hex)****Note 1:** If the number of characters are less than the maximum (20 for RTI, 32 for TTI), add a stop code (FF[H]) after the last character.**800111 to 80011F(H) - Service station's fax number (Service function 13)****800120 to 80012E(H) - Own fax number (User function 61)****800131(H) - Confidential ID (low - BCD)****800132(H) - Confidential ID (high - BCD)**

800141 to 800147(H) - Last power off time (Read only)

800141(H) - Year (BCD)

800142(H) - Month (BCD)

800143(H) - Day (BCD)

800144(H) - Hour

800145(H) - Minute

800146(H) - Second

800147(H) - 00: Monday, 01: Tuesday, 02: Wednesday, , 06: Sunday

800150 to 800151(H) - Optional equipment (Read only)**800150**

Bit 0: Memory card 0: Not installed, 1: Installed

Bit 1-4: Not used

Bit 5: Paper feed unit 0: Not installed, 1: Installed

Bit 6-7: Not used

800151

Bit 0-7: Not used

The following counters are on the System Parameter List. The names used on the system parameter list are in brackets.

800158 to 80015A(H) - TX counter (TX)

Address	High	Low
800158(H)	Tens digit	Unit digit
800159(H)	Thousands digit	Hundreds digit
80015A(H)	Millions digit	Ten thousands digit

Note: The following counters have the same data format as above.

80015B to 80015D(H) - RX counter (RX)**80015E to 800160(H) - Scan counter (SCN)****800161 to 800163(H) - Print counter (PRT)****800167 to 800169(H) - Paper feed counter: standard cassette (UPPER CASSETTE)****80016A to 80016C(H) - Paper feed counter: optional paper feed (CASSETTE 2)****80016D to 80016F(H) - Not used****800176 to 800178(H) - ADF counter (ADF)****80017C to 80017E(H) - Printer total jam counter (COPY JAM)****80017F to 800171(H) - Paper jam counter: standard cassette (UPPER CST JAM)****800182 to 800184(H) - Paper jam counter: optional paper feed (CST 2 JAM)****800185 to 800187(H) - Not used****80018B to 80018D(H) - Scanner total jam counter (DOC. JAM)****80018E to 800190(H) - Fusing exit jam counter (EJECT JAM)****800191 to 800193(H) - Registration jam counter (PAPER JAM)****800197 to 800199(H) - PM counter (PM)**

80019A to 80019C(H) - PM call interval: default 60,000 (PM DEFAULT)

80019D to 80019F(H) - Copy counter (COPY)

8001AC to 8001B7(H) - Not used

8001ED to 8001FC(H) - Excessive jam call parameters

Parameters	Address (H)		Initial Setting	Sys. Para. List
	ADF	Printer		
DEC (1 - 255; 0 = Disabled)	8001F5	8001F9	10 (H)	X
CALL (3 - 15; 0 = Disabled)	8001F6	8001FA	06(H)	Y
CLR (Low) (High)	8001F7	8001FB	30(H)	-
	8001F8	8001FC	00(H)	

Counters	Address (H)		Sys. Para. List
	ADF	Printer	
JAM : Jam counter used to place a service call	8001ED	8001F1	Z
NO-JAM1 : Counter used for JAM counter decrement	8001EE	8001F2	-
NO-JAM2 : Counter used for clearing the JAM counter	8001EF (Low)	8001F3 (Low)	-
	8001F0 (High)	8001F4 (High)	

800201 to 80022A(H) - Night timer period (User function 71)

- 800201 to 800203(H) - Setting #1 for Monday
- 800204 to 800206(H) - Setting #2 for Monday
- 800207 to 800209(H) - Setting #1 for Tuesday
- 80020A to 80020C(H) - Setting #2 for Tuesday
- 80020D to 80020F(H) - Setting #1 for Wednesday
- 800210 to 800212(H) - Setting #2 for Wednesday
- 800213 to 800215(H) - Setting #1 for Thursday
- 800216 to 800218(H) - Setting #2 for Thursday
- 800219 to 80021B(H) - Setting #1 for Friday
- 80021C to 80021E(H) - Setting #2 for Friday
- 80021F to 800221(H) - Setting #1 for Saturday
- 800222 to 800224(H) - Setting #2 for Saturday
- 800225 to 800227(H) - Setting #1 for Sunday
- 800228 to 80022A(H) - Setting #2 for Sunday

Program format

- First byte - Hour (BCD)
- Second byte - Minute (BCD)
- Third byte - 00(H): Timer start time, 01(H): Timer end time

800255 to 80025C(H) - Last RDS operation (Read only)

- 800255(H) - Year (BCD)
- 800256(H) - Month (BCD)
- 800257(H) - Day (BCD)
- 800258(H) - 00: Monday, 01: Tuesday, 02: Wednesday, , 06: Sunday
- 800259(H) - Hour
- 80025A(H) - Minute
- 80025B(H) - Second

80025D(H) - Daylight savings time setting (User function 62)

- 800260(H)** - Transmission monitor volume 00 - 07(H)
- 800261(H)** - Reception monitor volume 00 - 07(H)
- 800262(H)** - On-hook monitor volume 00 - 07(H)
- 800263(H)** - Dial monitor volume 00 - 07(H)
- 800264(H)** - Buzzer volume 00 - 07(H)
- 800265(H)** - Key acknowledgment tone volume 00 - 07(H)

800266 to 80026A(H) - Periodic service call parameters

Parameters		Address (H)
Call interval: 01 through 15 month(s) (BCD) 00: Periodic service call disabled		800266
Date and time of the next call	Day: 01 through 31 (BCD)	800269
	Hour: 01 through 24 (BCD)	80026A



800271 to 800273(H) - Effective term of automatic service calls

Parameters	Address (H)
Year: last two digits of the year (BCD)	800271
Month: 01 through 12 (BCD)	800272
Day: 01 through 31 (BCD)	800273

800274(H) - MODEM version (Read only)

800274(H) - Low (hex)

800275(H) - High (hex)

8002B6 to 8002B7(H) - Scanning top margin adjustment**8002B8 to 8002B9 (H)** - Scanning bottom margin adjustment

Refer to section 6.12 for details.

80034E(H) - Excessive jam alarm

Bit 3: Scanner excessive jam alarm 1: An alarm has occurred

Bit 4: Printer excessive jam alarm 1: An alarm has occurred

Either or both of these bits will change to 1 when an excessive jam alarm occurs. Reset each bit to 0 when you have solved the problem. The machine will not be able to detect excessive jams in future if you do not reset these bits.

80035F(H) - Print top margin (standard cassette: factory mode)**800360(H)** - Print top margin (optional paper feed unit: factory mode)**80036B(H)** - Print left margin (standard cassette: factory mode)**80036C(H)** - Print left margin (optional paper feed unit: factory mode)**800375(H)** - Print top margin (standard cassette: user function mode)**800376(H)** - Print top margin (optional paper feed unit: user function mode)**80037E(H)** - Print left margin (standard cassette: user function mode)**80037F(H)** - Print left margin (optional paper feed unit: user function mode)

Refer to section 6.12 for details about these parameters.

8003C7(H) - Details of the service call (hardware error)

0X(H): Fusing unit failure

21(H): Laser power is out of the specified range

3X(H): Polygonal mirror motor failure

5X(H): Power pack failure

When a service call was caused by a fusing lamp failure (codes 0X):

After fixing the problem, set printer switch 01 bit 0 to 1 and turn the power off/on. The machine resets this bit to 0, and restarts the machine to clear the service call.

When a service call occurred because of a different hardware failure:

If the problem remains after restarting the machine (power off/on), fix the hardware problem. The service call condition clears after power up.

8003D4 (H) - Number of copies after toner near end is detected**80061E to 800625 (H) - Scanning contrast threshold**

Refer to section 6.12 for details.

800626 to 800631 (H) - Scanner Video Processing Parameters

Refer to section 6.12 for details.

803050 to 8031CF(H) - Latest 64 error codes (Read only)

One error record consists of 6 bytes of data.

First error record start address - 803050(H)

Second error record start address - 803056(H)

Third error record start address – 80305C(H)

: : :

64th error record start address – 8031CA(H)

The format is as follows:

1st byte - Minute (BCD)

2nd byte - Hour (BCD)

3rd byte - Day (BCD)

4th byte - Month (BCD)

5th byte - Error code (low) [If the error code is 1-23, 23 is stored here.]

6th byte - Error code (high) [If the error code is 1-23, 01 is stored here.]

803856 to 803A67(H) - Latest 10 error communication records

One error communication record consists of 53 bytes. The format is as follows:

1st byte - Header

Bit 0: Communication result 0: OK, 1: NG

Bit 1: Document jam 1: Occurred

Bits 2 - 3: Not used

Bit 4: Technical data printout instead of personal codes 0: No, 1: Yes

Bit 5: Type of technical data 0: RX level, 1: Measure of error rate

Bit 6: Error report 0: Not printed, 1: Printed

Bit 7: Data validity 0: Not valid, 1: Valid

2nd to 5th bytes - Date and time when the communication started

2nd byte - Month (BCD)

3rd byte - Day (BCD)

4th byte - Hour (BCD)

5th byte - Minute (BCD)

6th and 7th bytes - Communication time

6th byte - Minutes (BCD)

7th byte - Seconds (BCD)

8th byte - Number of pages transmitted or received (Hex)

9th and 10th bytes - Personal code or number of total/burst error lines

If bit 4 of the 1st byte is 0:

9th byte - Personal code (low - BCD)

10th byte - Personal code (high - BCD)

If bit 4 of the 1st byte is 1:

9th byte - Number of total error lines (Hex)

10th byte - Number of burst error lines (Hex)

11th byte - File number (low - Hex)

12th byte - File number (high - Hex)

13th and 14th bytes - RX level or measure of error rate

If bit 5 of the 1st byte is 0:

13th byte - RX level (low - Hex)

14th byte - RX level (high - Hex)

If bit 4 of the 1st byte is 1:

13th byte - Measure of error rate (low - Hex)

14th byte - Measure of error rate (high - Hex)

15th byte - Final modem rate

Bits 0 to 3: Final modem speed

$\begin{pmatrix} \text{Bit0} \\ \text{Bit1} \\ \text{Bit2} \\ \text{Bit3} \end{pmatrix} = \begin{pmatrix} 1 \\ 0 \\ 0 \\ 0 \end{pmatrix}$	2.4 k	$\begin{pmatrix} 0 \\ 1 \\ 0 \\ 0 \end{pmatrix}$	4.8 k	$\begin{pmatrix} 1 \\ 1 \\ 0 \\ 0 \end{pmatrix}$	7.2 k	$\begin{pmatrix} 0 \\ 0 \\ 1 \\ 0 \end{pmatrix}$	9.6 k	$\begin{pmatrix} 1 \\ 0 \\ 1 \\ 0 \end{pmatrix}$	12.0 k	$\begin{pmatrix} 0 \\ 1 \\ 1 \\ 0 \end{pmatrix}$	14.4 k	$\begin{pmatrix} 1 \\ 1 \\ 1 \\ 0 \end{pmatrix}$	16.8 k
$\begin{pmatrix} \text{Bit0} \\ \text{Bit1} \\ \text{Bit2} \\ \text{Bit3} \end{pmatrix} = \begin{pmatrix} 0 \\ 0 \\ 0 \\ 1 \end{pmatrix}$	19.2 k	$\begin{pmatrix} 1 \\ 0 \\ 0 \\ 1 \end{pmatrix}$	21.6 k	$\begin{pmatrix} 0 \\ 1 \\ 0 \\ 1 \end{pmatrix}$	24.0 k	$\begin{pmatrix} 1 \\ 1 \\ 0 \\ 1 \end{pmatrix}$	26.4 k	$\begin{pmatrix} 0 \\ 0 \\ 1 \\ 1 \end{pmatrix}$	28.8 k	$\begin{pmatrix} 1 \\ 0 \\ 1 \\ 1 \end{pmatrix}$	31.2 k	$\begin{pmatrix} 0 \\ 1 \\ 1 \\ 1 \end{pmatrix}$	33.6 k

Bits 4 to 7: Final modem type

$\begin{pmatrix} \text{Bit4} \\ \text{Bit5} \\ \text{Bit6} \\ \text{Bit7} \end{pmatrix} = \begin{pmatrix} 1 \\ 0 \\ 0 \\ 0 \end{pmatrix}$	V.27ter	$\begin{pmatrix} 0 \\ 1 \\ 0 \\ 0 \end{pmatrix}$	V.29	$\begin{pmatrix} 1 \\ 1 \\ 0 \\ 0 \end{pmatrix}$	V.33	$\begin{pmatrix} 0 \\ 0 \\ 1 \\ 0 \end{pmatrix}$	V.17 (Long)	$\begin{pmatrix} 1 \\ 0 \\ 1 \\ 0 \end{pmatrix}$	V.17 (Short)				
$\begin{pmatrix} \text{Bit4} \\ \text{Bit5} \\ \text{Bit6} \\ \text{Bit7} \end{pmatrix} = \begin{pmatrix} 1 \\ 0 \\ 0 \\ 1 \end{pmatrix}$	V.34	$\begin{pmatrix} 0 \\ 1 \\ 0 \\ 1 \end{pmatrix}$	2400 baud	$\begin{pmatrix} 1 \\ 0 \\ 0 \\ 1 \end{pmatrix}$	V.34	$\begin{pmatrix} 1 \\ 0 \\ 0 \\ 1 \end{pmatrix}$	3000 baud	$\begin{pmatrix} 0 \\ 1 \\ 1 \\ 1 \end{pmatrix}$	3200 baud	$\begin{pmatrix} 0 \\ 0 \\ 1 \\ 1 \end{pmatrix}$	2800 baud	$\begin{pmatrix} 1 \\ 0 \\ 1 \\ 1 \end{pmatrix}$	3429 baud



16th byte to 35th byte - Remote terminal's ID (RTI, TSI or CSI) (ASCII)

36th byte - Communication modes, byte #1

Bits 0 - 1: Resolution used

$\begin{pmatrix} \text{Bit 0} \\ \text{Bit 1} \end{pmatrix} = \begin{pmatrix} 1 \\ 0 \end{pmatrix} : \text{Standard}$ $\begin{pmatrix} 0 \\ 1 \end{pmatrix} : \text{Detail}$, $\begin{pmatrix} 1 \\ 1 \end{pmatrix} : \text{Fine}$

Bit 2: Not used

Bit 3: ECM 0: Off, 1: On

Bits 4 to 7: Communication mode used

$\begin{pmatrix} \text{Bit4} \\ \text{Bit5} \\ \text{Bit6} \\ \text{Bit7} \end{pmatrix} = \begin{pmatrix} 0 \\ 0 \\ 0 \\ 0 \end{pmatrix}$: Normal	$\begin{pmatrix} 1 \\ 0 \\ 0 \\ 0 \end{pmatrix}$: Confidential	$\begin{pmatrix} 0 \\ 1 \\ 0 \\ 0 \end{pmatrix}$: Polling	$\begin{pmatrix} 1 \\ 1 \\ 0 \\ 0 \end{pmatrix}$: Transfer
$\begin{pmatrix} \text{Bit4} \\ \text{Bit5} \\ \text{Bit6} \\ \text{Bit7} \end{pmatrix} = \begin{pmatrix} 0 \\ 0 \\ 1 \\ 0 \end{pmatrix}$: Forwarding	$\begin{pmatrix} 1 \\ 0 \\ 1 \\ 0 \end{pmatrix}$: Automatic	$\begin{pmatrix} 0 \\ 1 \\ 1 \\ 0 \end{pmatrix}$: Service Call		

37th byte - Communication modes, byte #2

Bit 0: TX or RX

0: TX, 1: RX

Bit 1: Reduction in TX

0: Not reduced, 1: Reduced

Bit 2: Batch transmission

0: Not used, 1: Used

Bit 3: Send later transmission

0: Not used, 1: Used

Bit 4: Transmission from

0: ADF, 1: Memory

Bits 5 to 7: Not used

38th byte - Number of errors during communication (Hex)

39th to 41st byte - 1st error code and page number where the error occurred

39th byte - Page number where the error occurred (Hex)

40th byte - Error code (low - BCD)

41st byte - Error code (high - BCD)

42nd to 44th byte - 2nd error code and page number where the error occurred

45th to 47th byte - 3rd error code and page number where the error occurred

48th to 50th byte - 4th error code and page number where the error occurred

51st to 53rd byte - 5th error code and page number where the error occurred

806126 to 806265(H) - Dedicated tx parameters for Quick Dial 01 - 30 and Speed Dial #00 - #49.

As explained in section 4.4, each set of dedicated tx parameters consists of 8 bytes.

806126 to 806129(H) - Dedicated tx parameters for Quick 01

80612A to 80612D(H) - Dedicated tx parameters for Quick 02

80612E to 806131(H) - Dedicated tx parameters for Quick 03

:

80619A to 80619D(H) - Dedicated tx parameters for Quick 30

80619E to 8061A1(H) - Dedicated tx parameters for Speed #00

8061A2 to 8061A5(H) - Dedicated tx parameters for Speed #01

8061A6 to 8061A9(H) - Dedicated tx parameters for Speed #03

:

806262 to 806265(H) - Dedicated tx parameters for Speed #49

F80006 to F8000E(H) - ROM part number and suffix (ASCII)

5. PREVENTIVE MAINTENANCE

5.1 SPECIAL TOOLS AND LUBRICANTS

- Flash/SRAM data copy tool (P/N: A1939353 or H5159100)
- Flash/SRAM data copy board (P/N: A1939351)

5.2 PM TABLE

Scanner / ADF

C: Clean, R: Replace

Item	30K	60K	Notes
CIS Glass	C (user)	C (user)	Soft cloth and water
White Roller	C (user)	C (user)	Soft cloth and water
ADF Feed Roller Assembly	C (user)	R	Soft cloth and water
ADF Separation Roller	C (user)	R	Soft cloth and water

Printer

Item	30K	60K	Notes
Paper Feed Roller	C (user)	C	Soft cloth and water
Separation Pad	C (user)	R	Soft cloth and water
Fusing Thermistor		R	
Hot Roller Strippers		R	4 pieces used
Hot Roller		R	
Pressure Roller (Fusing)		R	
Transfer Roller		R	
Cleaning Pad	R (user) Replaced after installing a new cartridge.		A cleaning pad is included with the cartridge.

Paper Feed Unit (Optional)

Item	30K	60K	Notes
Feed Roller	C (user)	R	Soft cloth and water
Friction Pad	C (user)	R	Soft cloth and water

6. REPLACEMENT AND ADJUSTMENT

WARNING

The machine contains a laser beam generator. Laser beams can cause permanent eye damage. Do not open the laser unit or look along the laser beam path while the main power is on.

CAUTION

Before starting disassembly, be sure to print all message files in the SAF memory. Then, turn off the main switch and disconnect the power cord for safety.

Lithium Battery: The danger of explosion exists if a battery of this type is incorrectly replaced. Replace only with the same or equivalent type recommended by the manufacturer. Discard used batteries in accordance with the manufacturer's instructions.

6.1 EXTERIOR

6.1.1 TOP COVER

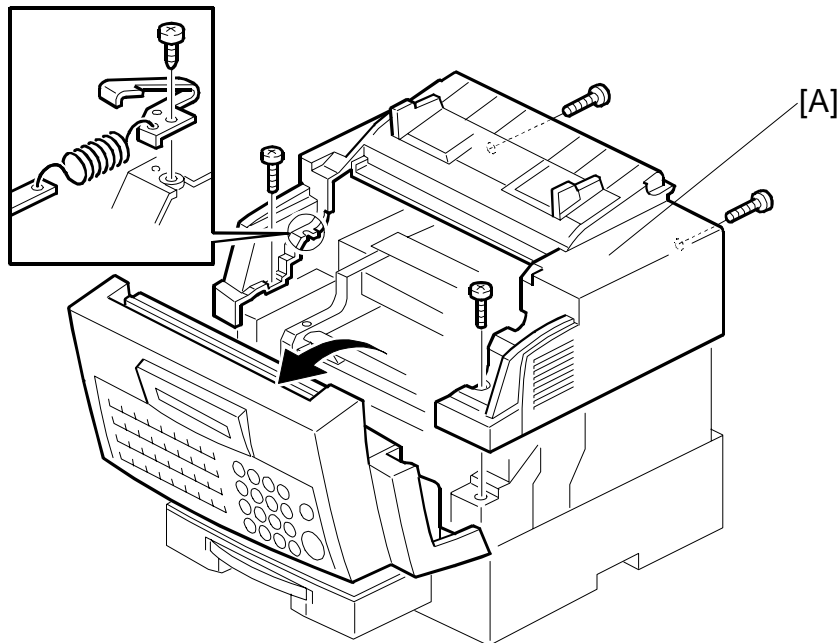

H545R514.WMF

A: Top Cover (5 screws, 1 spring plate)

Replacement
Adjustment

6.1.2 OPERATION PANEL

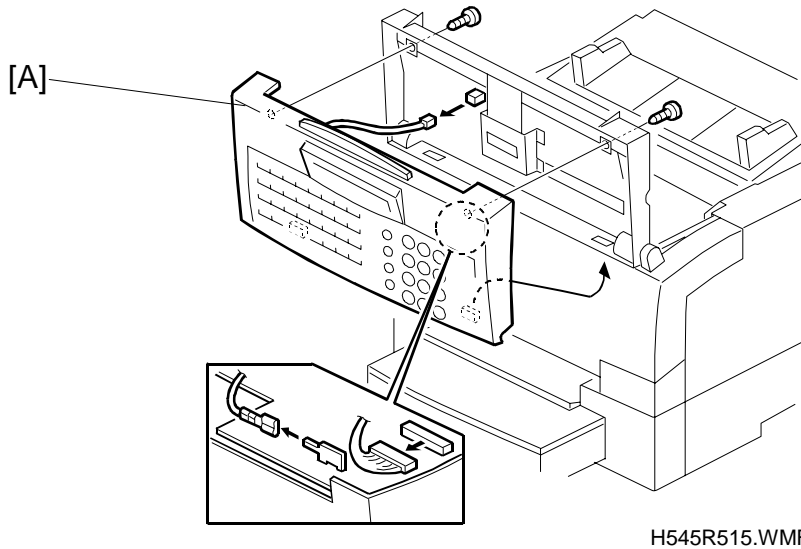

A: Operation Panel (2 screws, 2 connectors, 1 grounding wire, and 2 hooks)

6.2 ADF

6.2.1 FEED ROLLER ASSEMBLY

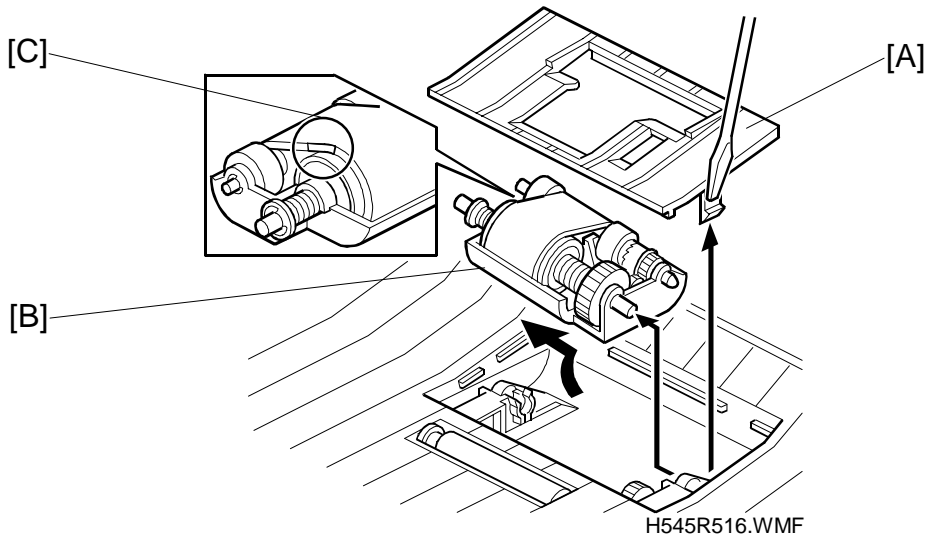

A: ADF Roller Cover (2 hooks)

B: Feed Roller Assembly

NOTE: If installing a feed belt [C], be sure that the side with the white paint faces the correct direction, as shown.

6.2.2 SEPARATION ROLLER

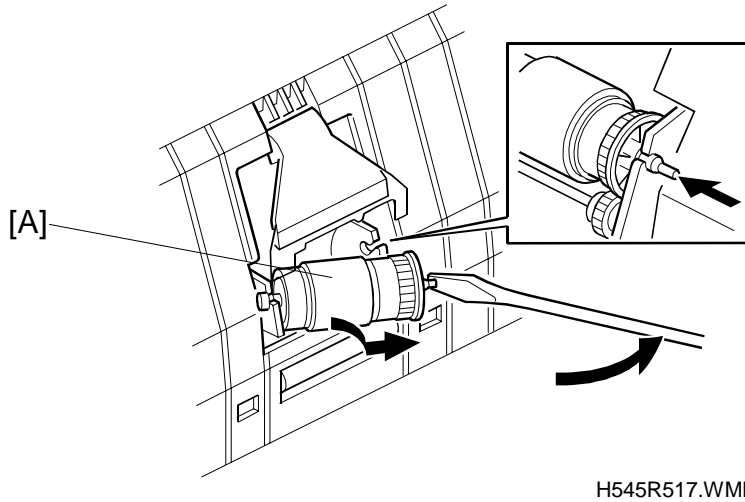

A: Separation Roller

6.3 SCANNER

6.3.1 SCANNER UNIT DISASSEMBLY

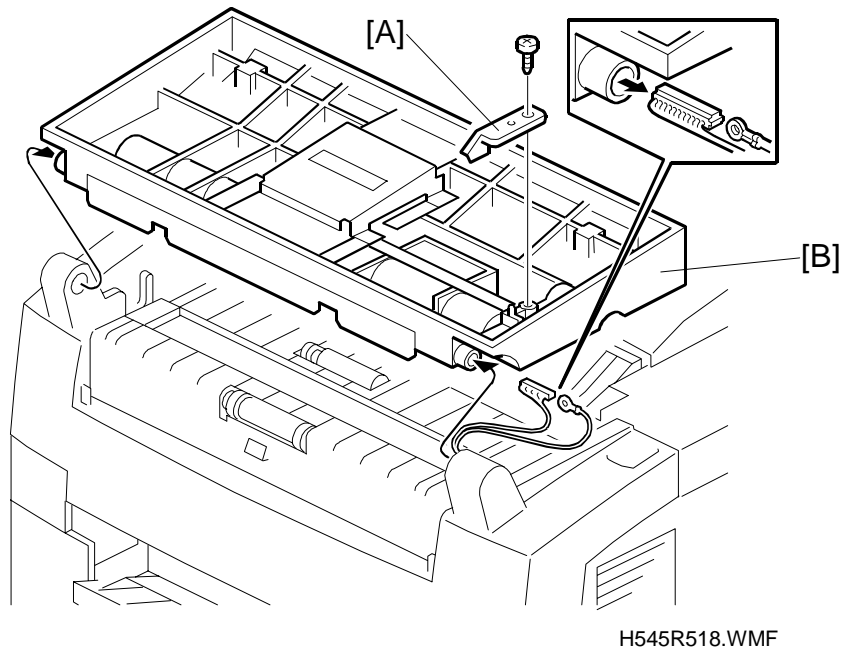

First, remove the top cover and the operation panel.

A: Stopper (1 screw)

B: ADF Upper Unit (1 screw with grounding wire)

Replacement
Adjustment

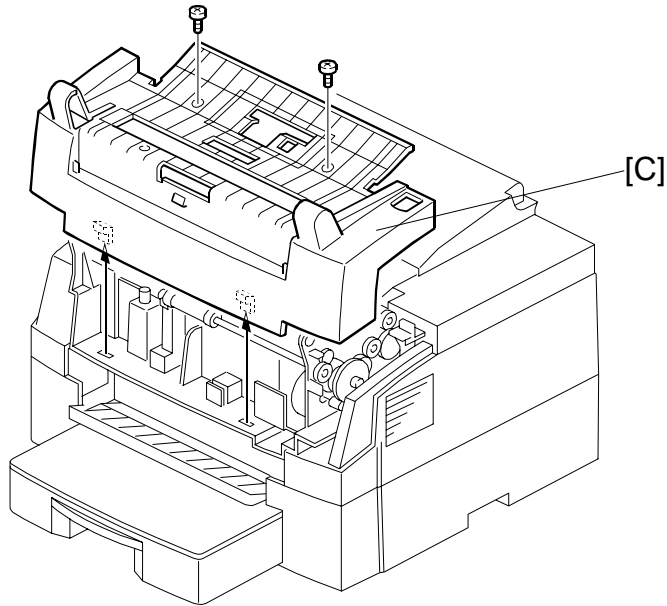

H545R519.WMF

C: Scanner Cover (2 screws, 2 hooks)

6.3.2 SCANNER MOTOR

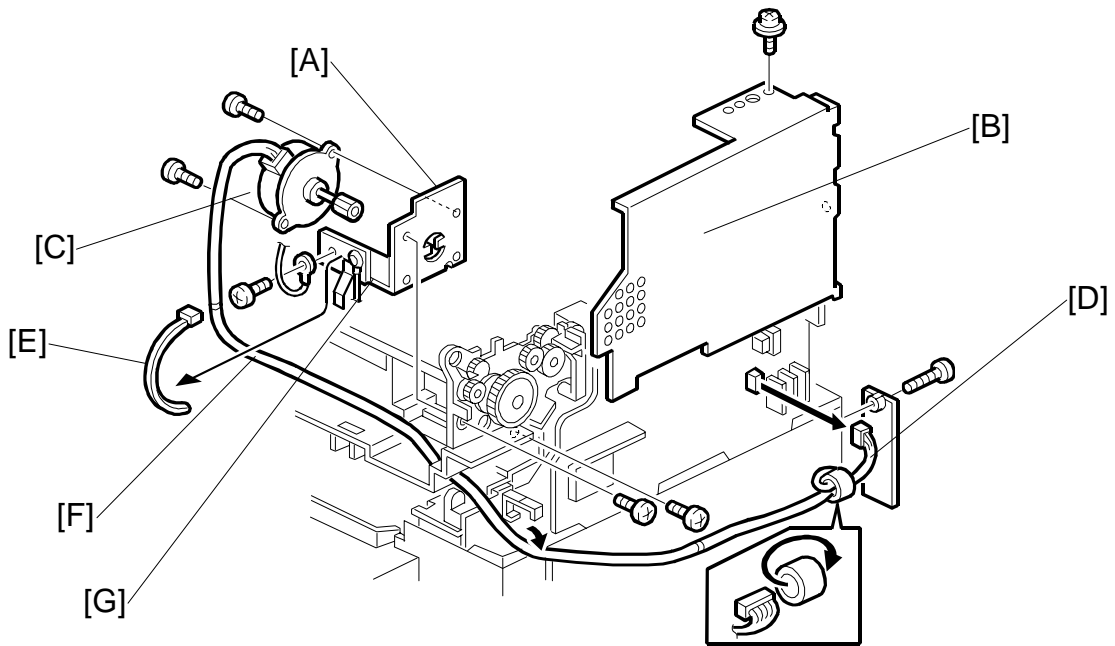

H545R522.WMF

First, remove the clamp [E].

A: Scanner Motor Assembly (2 screws)

B: FCU Cover (2 screws, PC Interface Cover [D])

C: Scanner Motor (2 screws, 1 connector)

NOTE: After replacing the Scanner Motor Assembly, bring the wire mesh cover around harness [F] into contact with bracket [G] using the new clamp [E].

6.3.3 R1/R2 ROLLERS

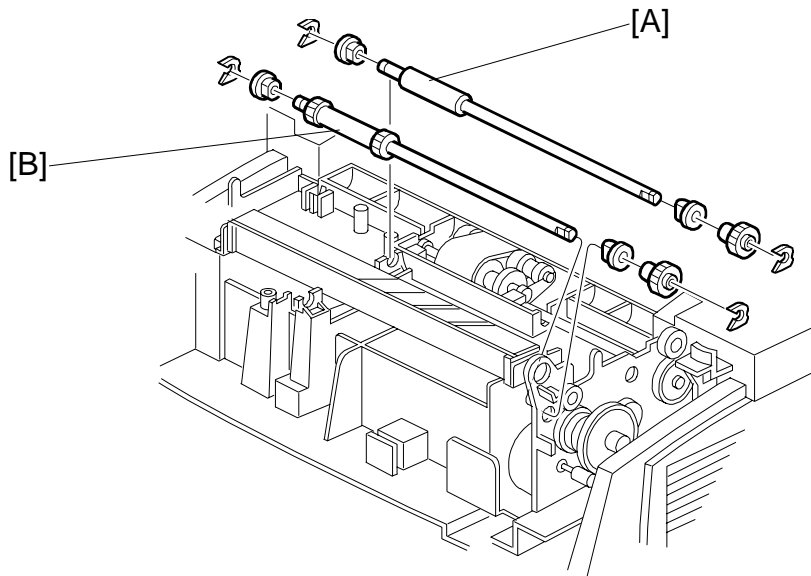

H545R521.WMF

- A: R1 Roller (2 plastic clips, 2 bushings, 1 gear clipped on the shaft)
- B: R2 Roller (2 plastic clips, 2 bushings, 1 gear clipped on the shaft)

6.3.4 CONTACT IMAGE SENSOR ASSEMBLY

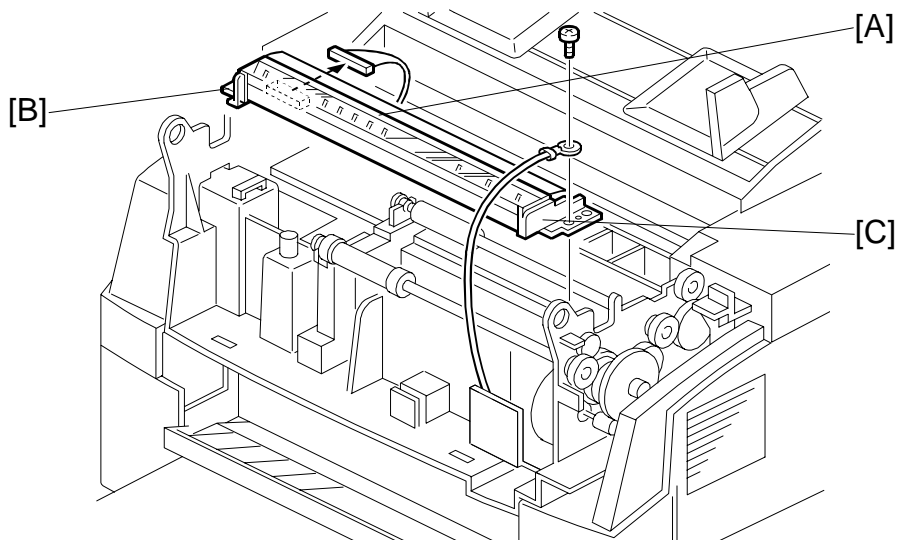

H545R520.WMF

- A: Contact Image Sensor Assembly (1 connector, 1 screw with grounding wire)

<p>⚠ CAUTION Do not remove the brackets [B] and [C].</p>

Replacement
Adjustment

6.3.5 SCANNER UNIT

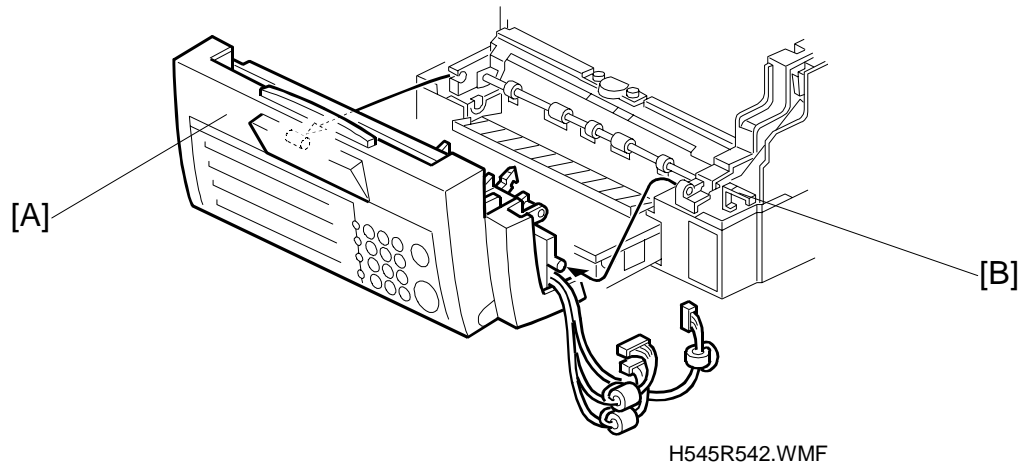

First, remove the top cover and the FCU cover (refer to section 6.3.2).

A: Scanner Unit (2 hooks, 3 connectors, 1 screw with grounding wire)

NOTE: When placing the cables in the clamp [B], put the 2 thin cables underneath the thick cable.

(The thick cable has multicolored wires and the thin ones have only black wires.)

6.4 LASER PRINTING COMPONENTS

6.4.1 LASER UNIT

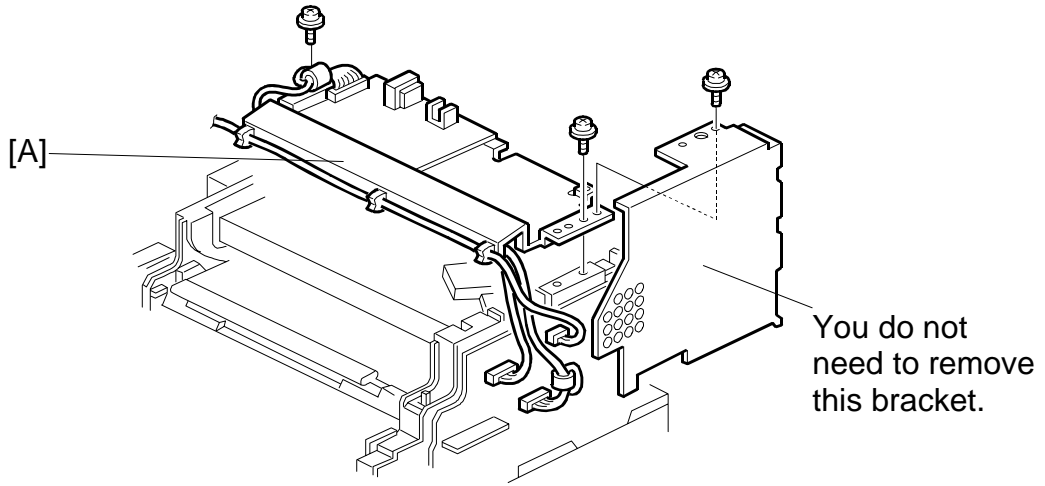

H545R527.WMF

First, remove the top cover, and then lift the NCU bracket [A] (3 screws).

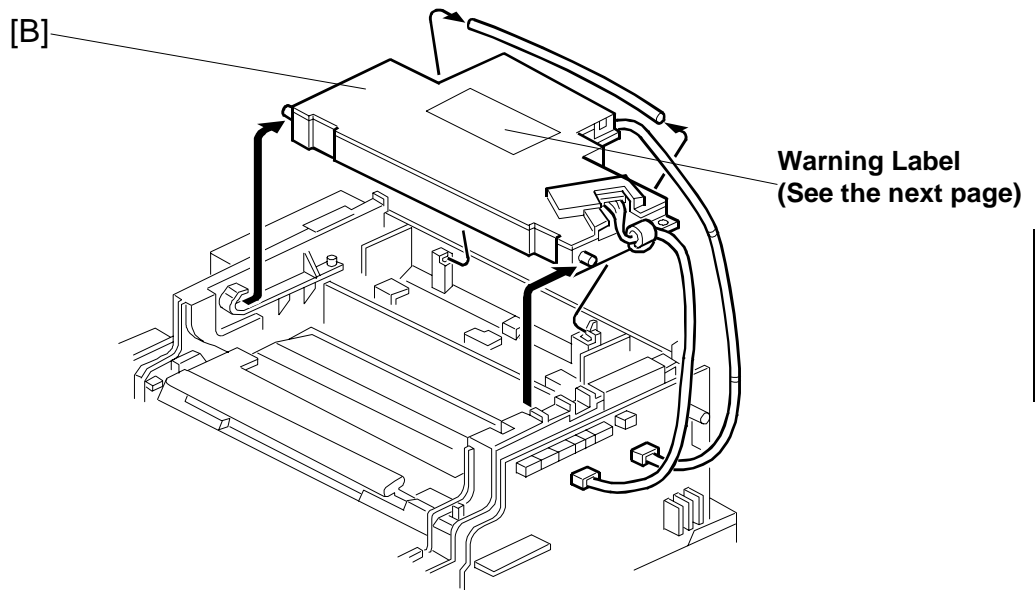

H545R523.WMF

B: Laser Unit (2 connectors, 1 spring rod)

Replacement
Adjustment

 WARNING
Laser beams can cause permanent eye damage. Do not open the laser unit or look along the laser beam path while the main power is on.

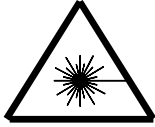
DANGER	
INVISIBLE LASER RADIATION WHEN OPEN AVOID DIRECT EXPOSURE TO BEAM	
CAUTION INVISIBLE LASER RADIATION WHEN OPEN AVOID EXPOSURE TO BEAM	VORSICHT UNSIHTBARE LASERSTRAHLUNG, WENN ABDECKUNG GEOFFNET NICHT DEM STRAHL AUSSETZEN

H545R500.WMF

6.5 DEVELOPMENT

6.5.1 TRANSFER ROLLER

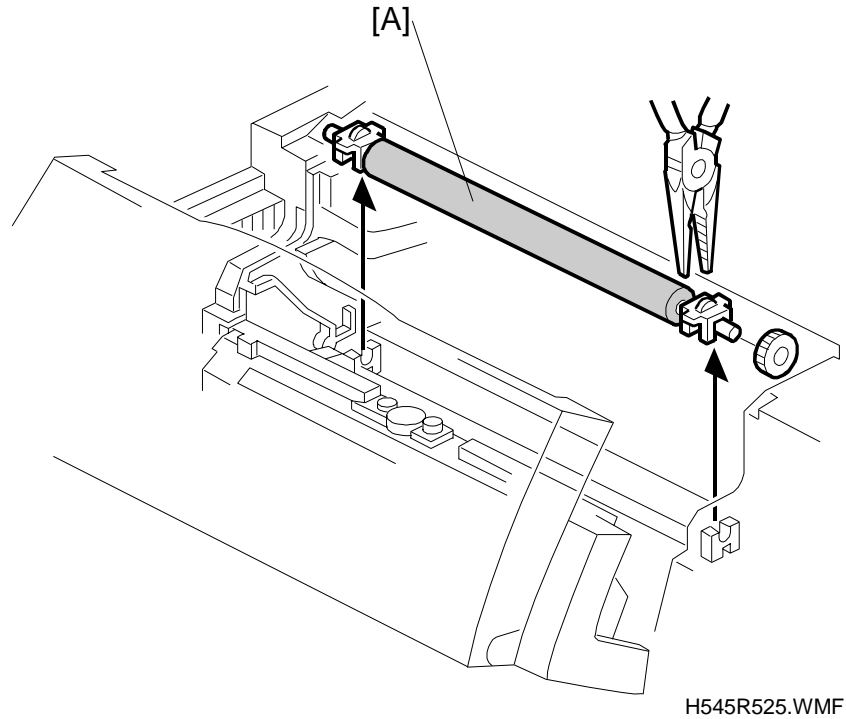

First, open the scanner unit, then remove the cartridge.

A: Transfer Roller (1 gear, 2 clips)

6.6 FUSING

6.6.1 FUSING UNIT

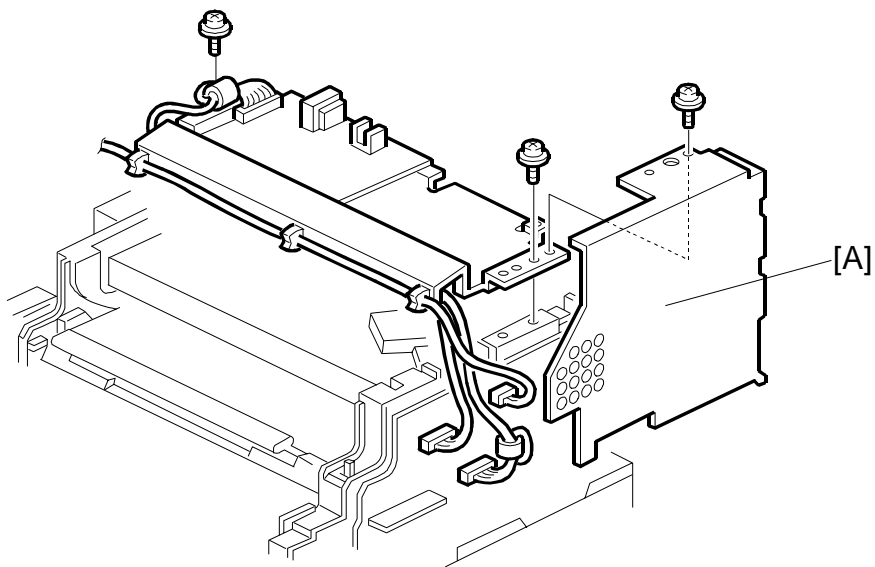

H545R527.WMF

First, remove the top cover. Then remove the FCU cover [A].

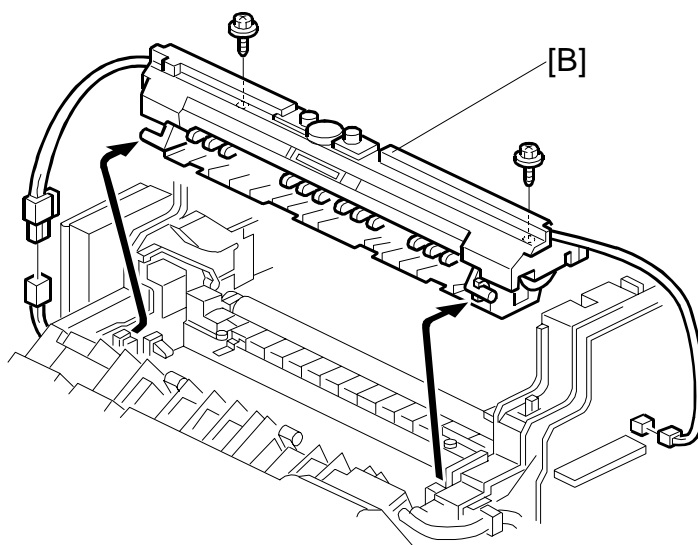

H545R526.WMF

B: Fusing Unit (2 screws, 2 connectors)

6.6.2 THERMISTOR

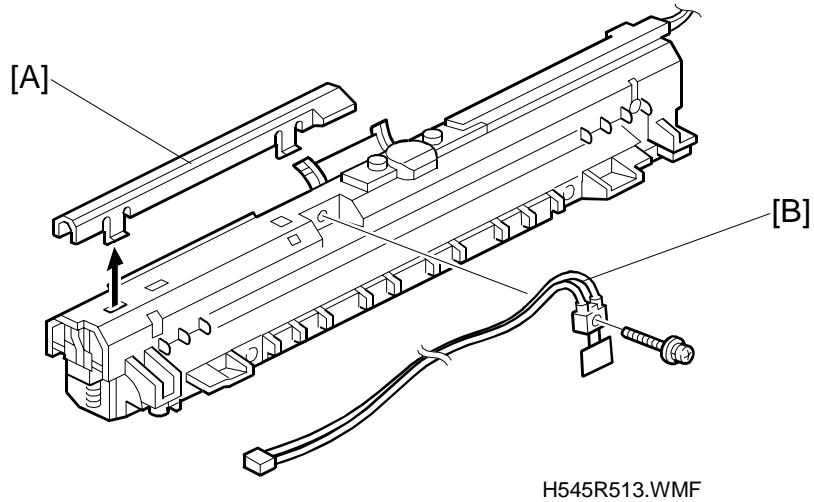

- A: Thermistor Cover (4 hooks)
- B: Thermistor (1 screw)

6.6.3 HOT ROLLER STRIPPERS

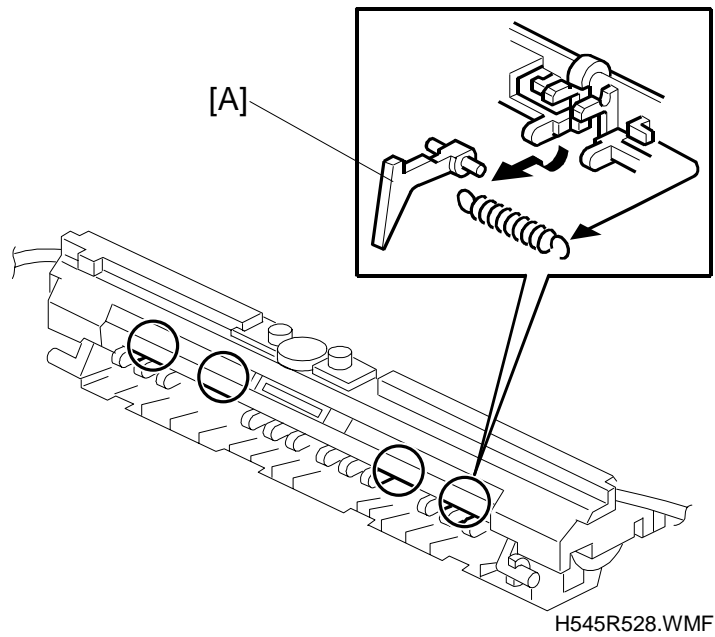

- A: Hot Roller Strippers (1 spring each)
- NOTE: Be careful not to lose the springs.**

Replacement
Adjustment

6.6.4 FUSING LAMP AND HOT ROLLER

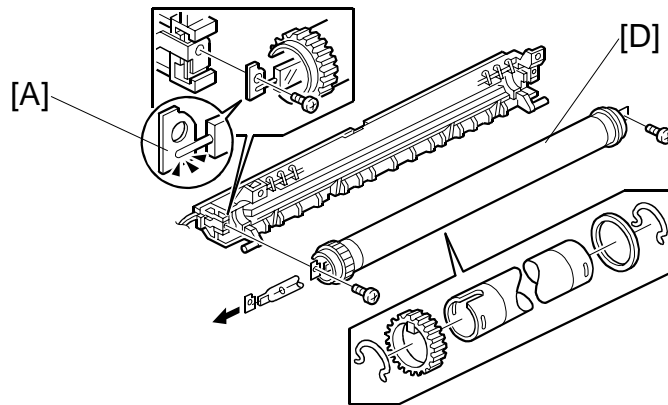

H545R510.WMF

A: Fusing Lamp (2 screws)

NOTE: When installing a new fusing lamp, be sure that it is installed the correct way around, as shown.

⚠ CAUTION
 Be careful not to touch the glass surface.

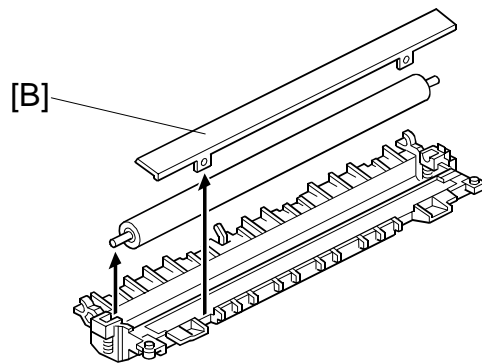

H545R509.WMF

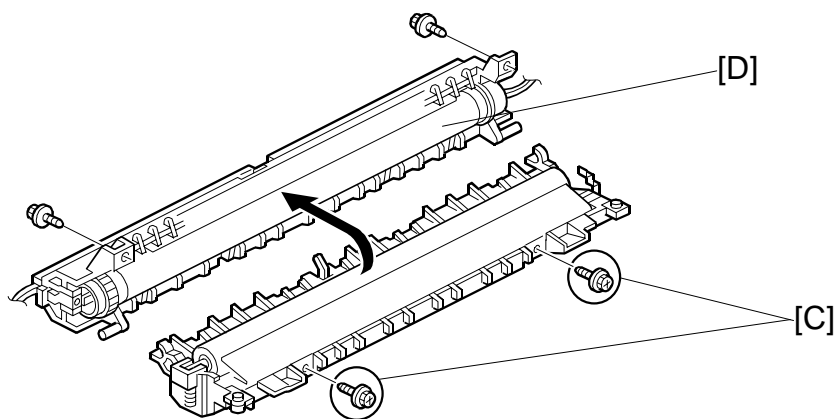

H545R512.WMF

First, remove the bracket [B] and 2 screws [C], then the fusing upper and lower units come apart.

D: Hot Roller

6.6.5 PRESSURE ROLLER

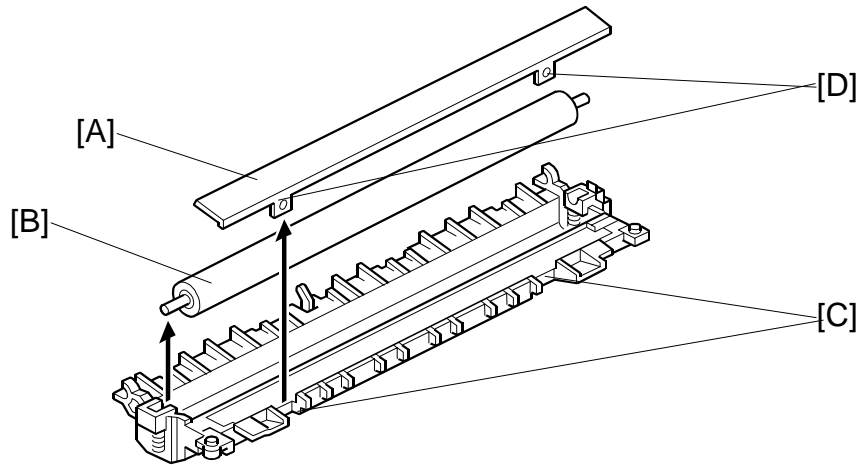

H545R509.WMF

A: Bracket (2 screws)

NOTE: Fit the projections [C] into the holes [D] when replacing this bracket.

B: Pressure Roller

6.6.6 THERMOSTAT AND THERMOFUSE

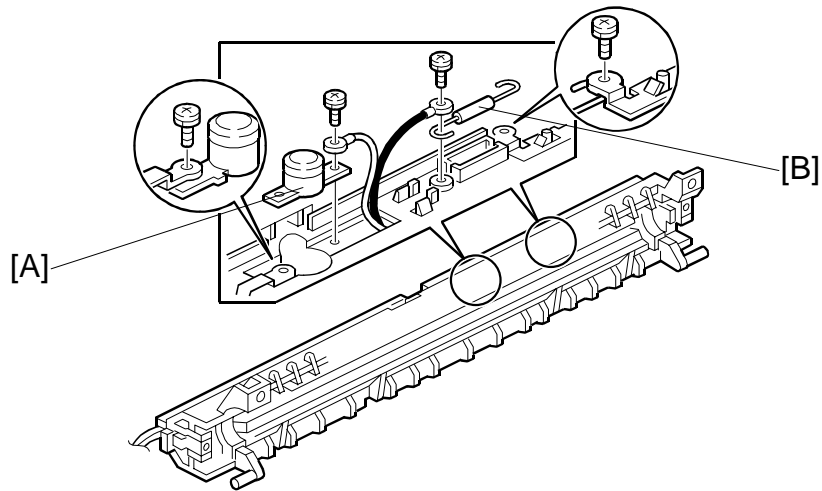

H545R511.WMF

A: Thermostat (2 screws)

B: Thermofuse (2 screws) – Europe model only

Replacement
Adjustment

6.7 PCBs

6.7.1 NCU

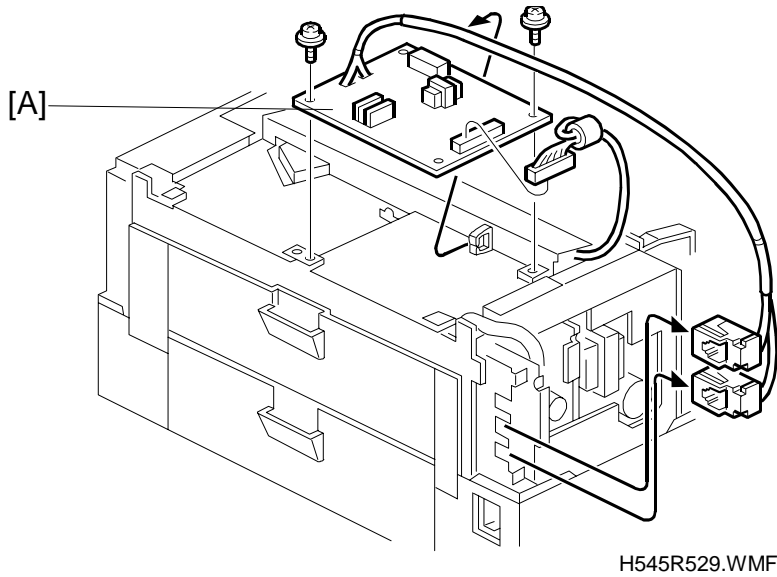

First, remove the Top Cover.

A: NCU (2 screws, 1 connector)

6.7.2 PSU

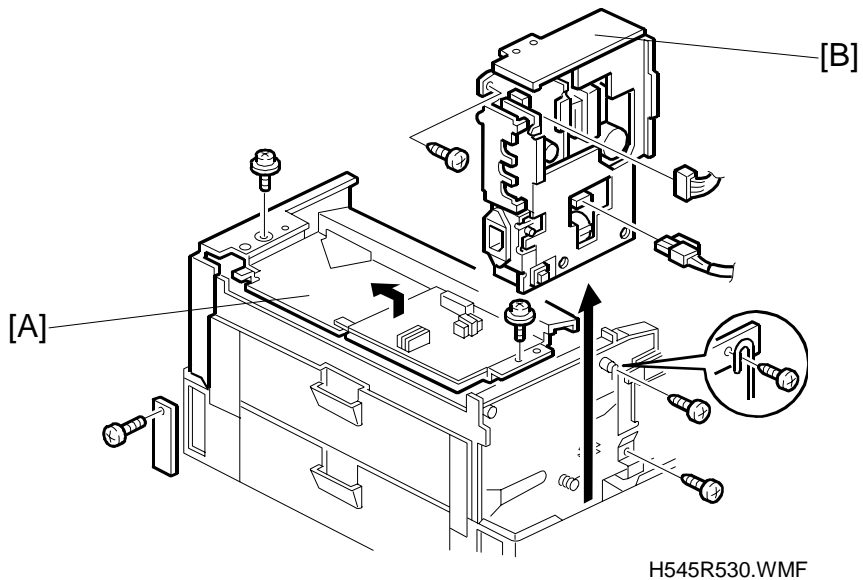

First, remove the Top Cover.

A: NCU Bracket (2 screws)

B: PSU (3 screws, 2 connectors)

6.7.3 POWER PACK

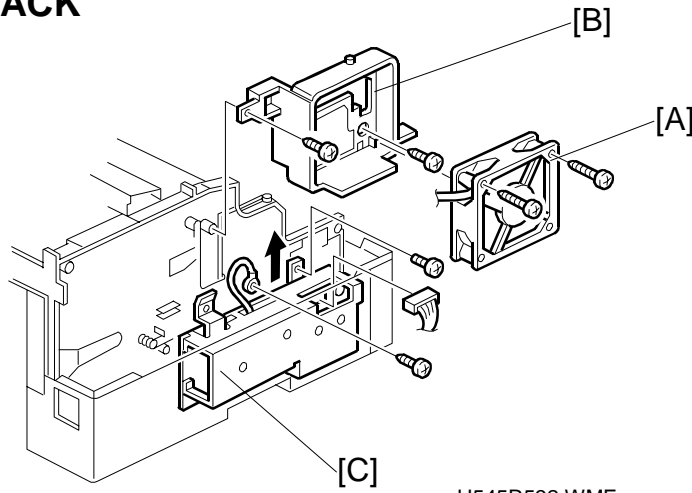

H545R532.WMF

First, remove the PSU.

A: Fan Motor (2 screws)

B: Fan Duct (2 screws)

C: Power Pack (1 screw, 1 screw with grounding wire, 1 connector)

6.7.4 FCU

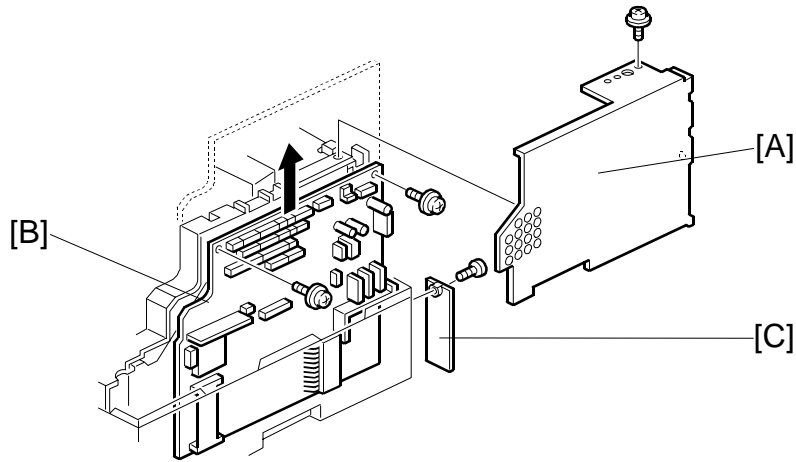

H545R531.WMF

Replacement
Adjustment

After installing the new FCU, transfer the RAM data from the old FCU using service function 12 (refer to section 4.1.24).

First, remove the Top Cover.

A: FCU Cover (2 screws, PC Interface Cover [C])

B: FCU (2 screws, 23 connectors)

NOTE: Turn on SW1 on the new FCU.

6.8 PAPER FEED

6.8.1 SEPARATION PAD

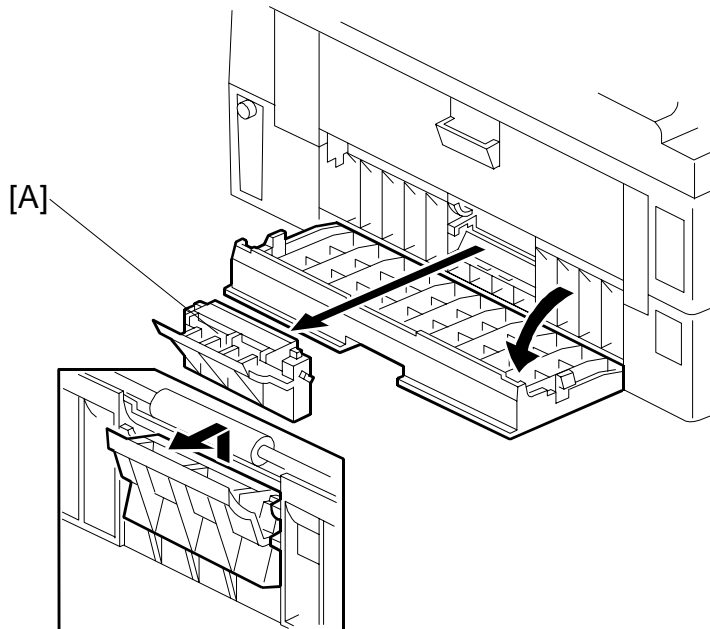

H545R507.WMF

A: Separation Pad Assembly

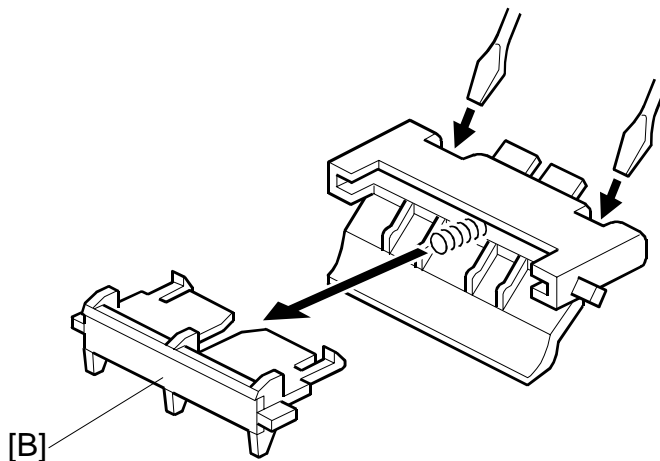

H545R508.WMF

B: Separation Pad

6.8.2 PAPER FEED UNIT ASSEMBLY AND PAPER FEED MOTOR

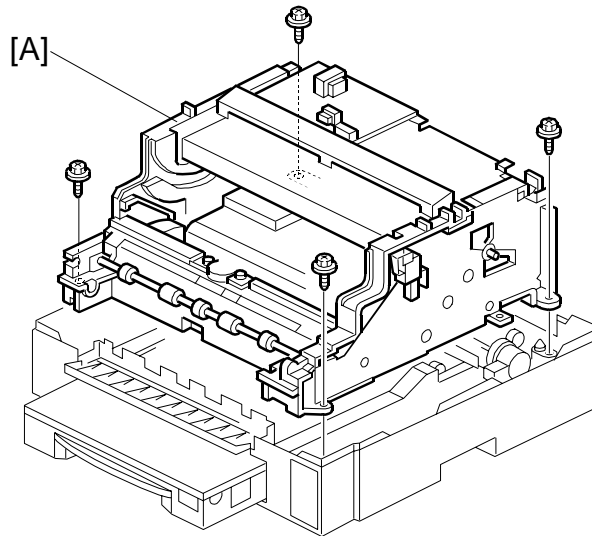

H545R535.WMF

If the FCU, PSU and Power Pack were not removed previously, remove them now.
(See section 6.7)

Then remove the **Main Frame [A]**.

A: Main Frame (4 screws)

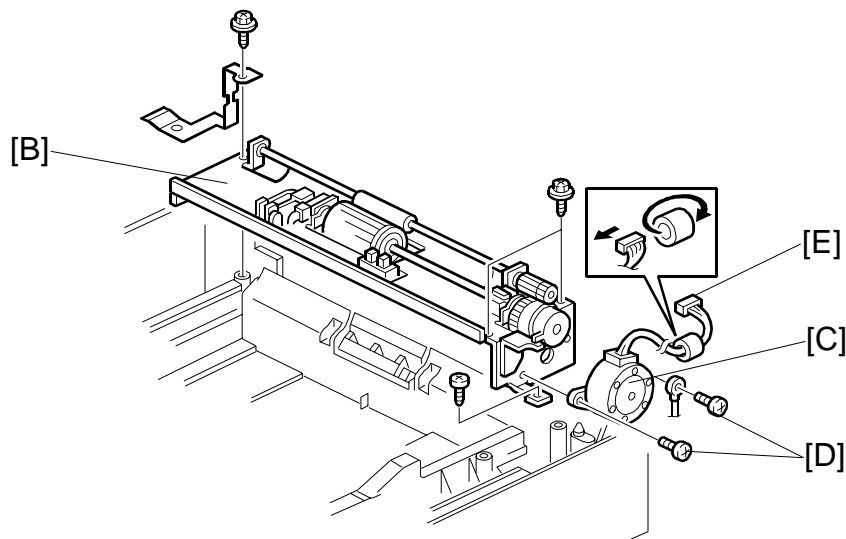

H545R534.WMF

B: Paper Feed Unit Assembly (4 screws)

C: Paper Feed Motor (1 short screw with spacer and grounding wire, 1 screw with spacer)

NOTE: 1) Use 4mm screws [D] to secure the motor.

2) The side of the motor with the harness [E] must be facing upward.

Replacement
Adjustment

6.8.3 PAPER END SENSOR AND REGISTRATION SENSOR

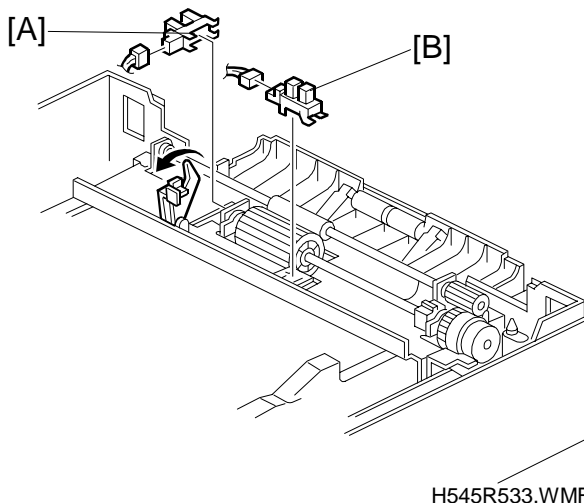

- A: Paper-End-Sensor (1 connector)
- B: Registration Sensor (1 connector)

6.8.4 PAPER FEED ROLLER/CLUTCH AND TRANSPORT ROLLER

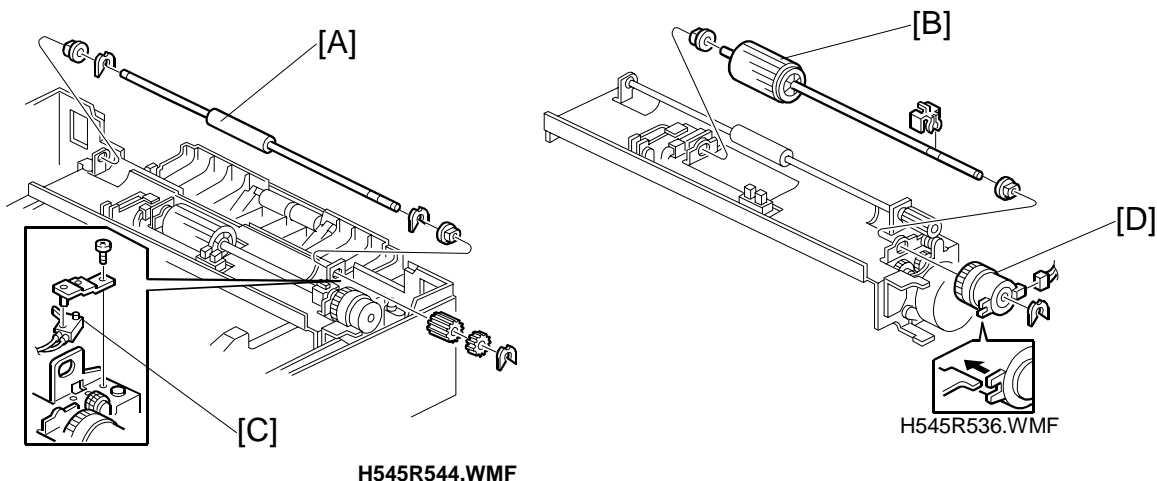

First, remove the Paper Feed Unit Assembly.

- A: Transport Roller (3 plastic clips, 2 bushes, 2 gears)
- B: Paper Feed Roller (1 clip, 1 bush, 2 plastic clips)
- C: Rear Cover Sensor (1 screw)
- D: Paper Feed Clutch (1 E-ring, 1 connector)

NOTE: Make sure that the paper feed roller shaft rotates clockwise when viewed from the right of the machine.

6.9 OTHERS

6.9.1 INTERLOCK SWITCHES

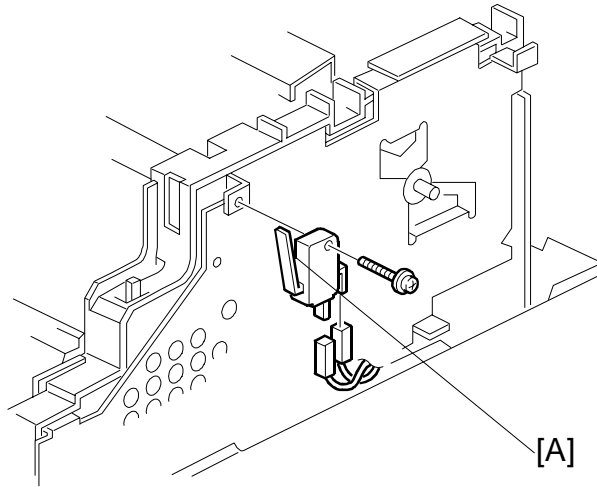

H545R540.WMF

First, remove the Top Cover, then remove the FCU (see section 6.7.4).

A: Interlock Switch - 24V (1 screw)

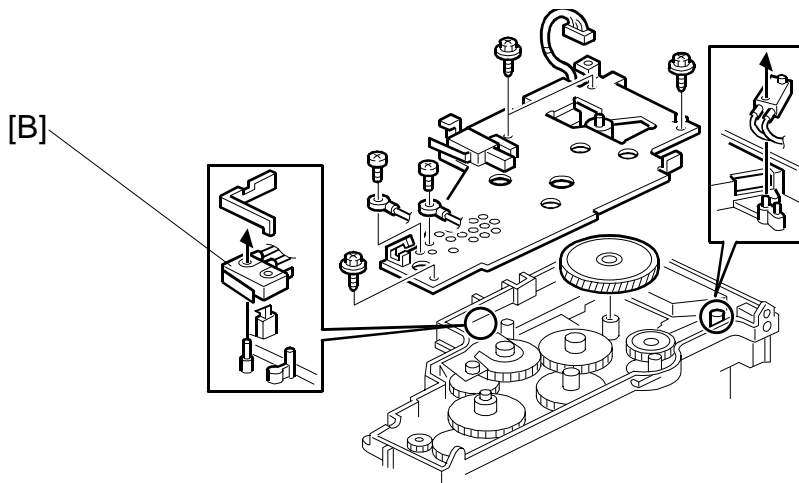

H545R538.WMF

B: Interlock Switch - 5V (1 screw)

Replacement
Adjustment

6.9.2 MAIN MOTOR

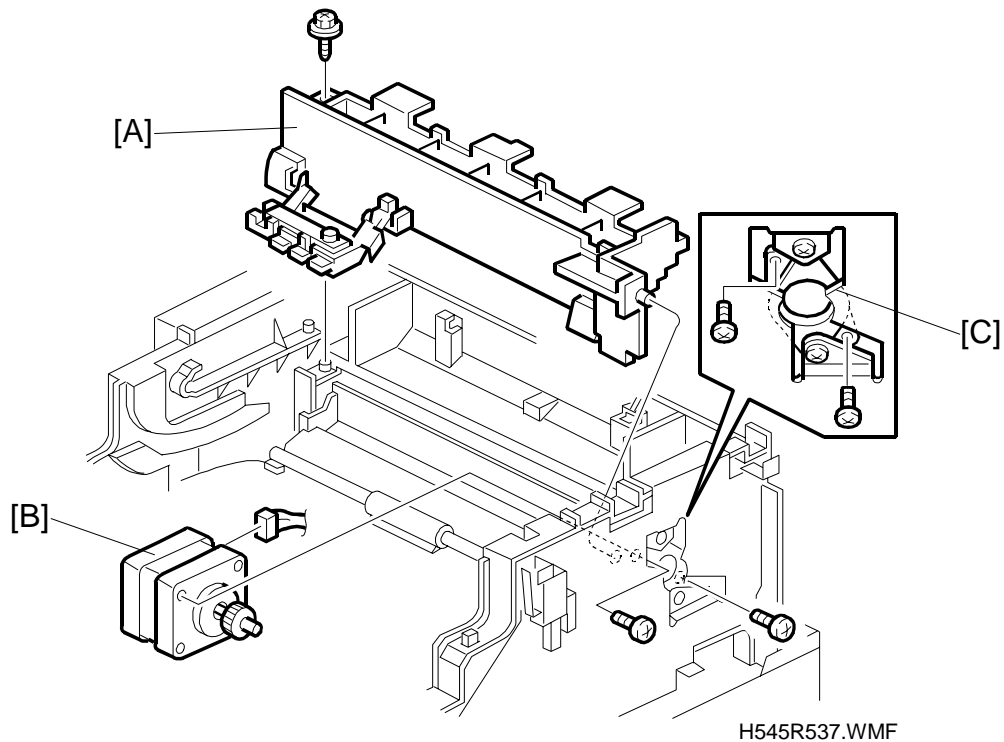

First, remove the Top Cover, then remove the Laser Unit (see section 6.4.1) and the FCU (see section 6.7.4).

A: Stay (1 screw)

B: Main Motor (2 screws)

NOTE: Do not remove the damper [C], because it is factory adjusted.

6.9.3 REGISTRATION ROLLER

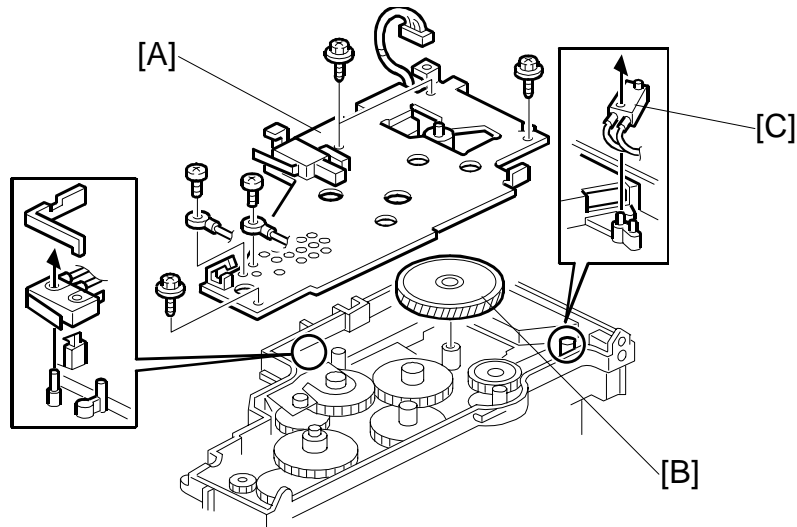

H545R538.WMF

First, remove the Main Frame (see section 6.8.1).

A: Right Bracket (5 screws, 2 grounding wire)

NOTE: When replacing the Right Bracket [A], do not forget to put back the coupled gear [B] and microswitch [C].

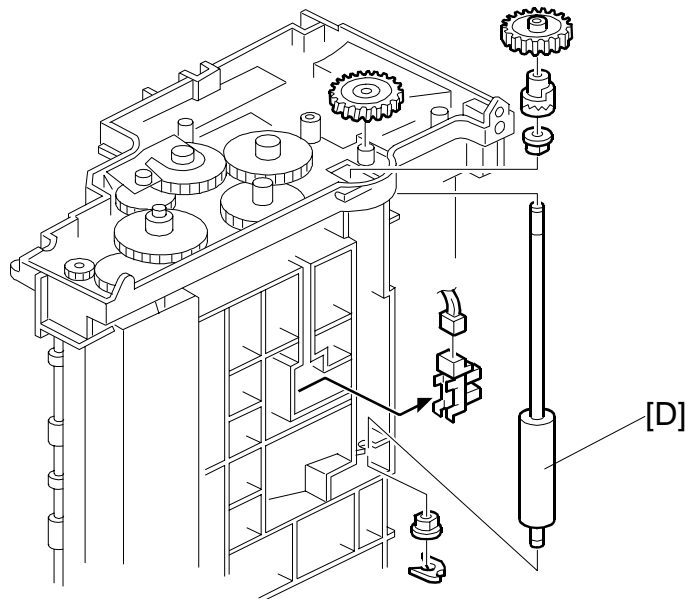

H545R539.WMF

Replacement Adjustment

Remove the Rear Lower Cover, then stand the Main Frame on its side, as shown.

NOTE: Do not let the gears drop while standing the Main Frame on its side.

D: Registration Roller (1 coupled gear, 1 gear, 2 bushings, 1 plastic clip, and a one-way clutch gear)

6.9.4 TONER END SENSOR

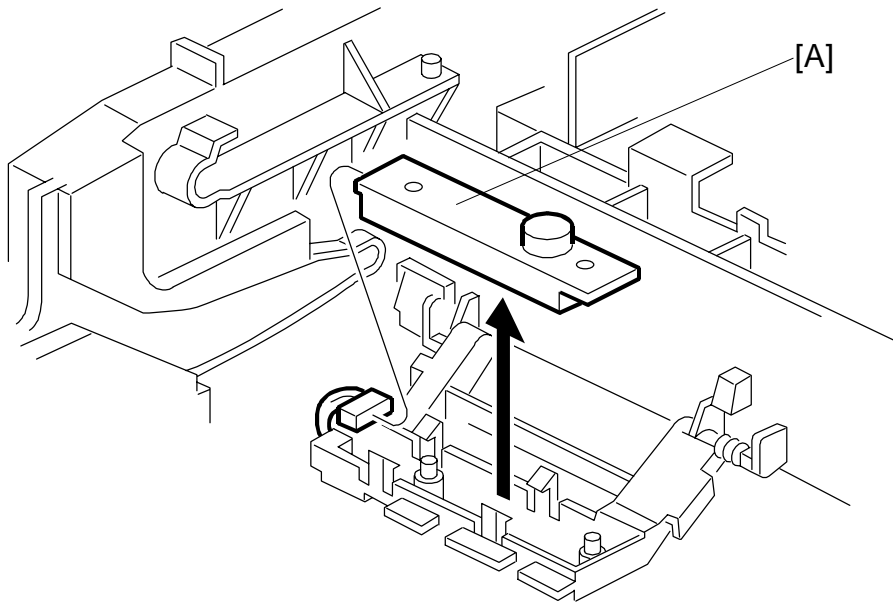

H545R541.WMF

A: Toner End Sensor (1 connector)

6.10 PAPER FEED UNIT (OPTIONAL)

6.10.1 TRANSPORT ROLLER

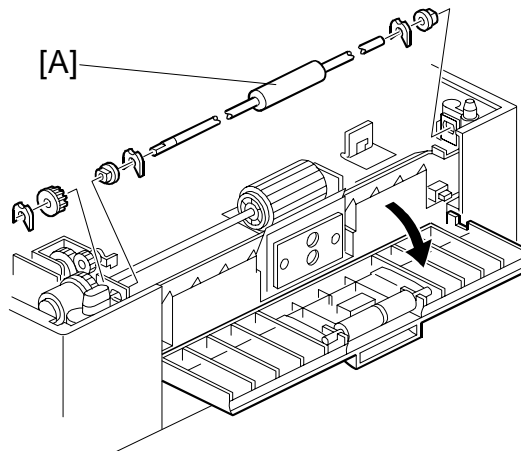

H545R502.WMF

A: Transport Roller (3 plastic clips, 2 bushings, 1 gear)

6.10.2 PAPER FEED ROLLER AND PAPER FEED CLUTCH

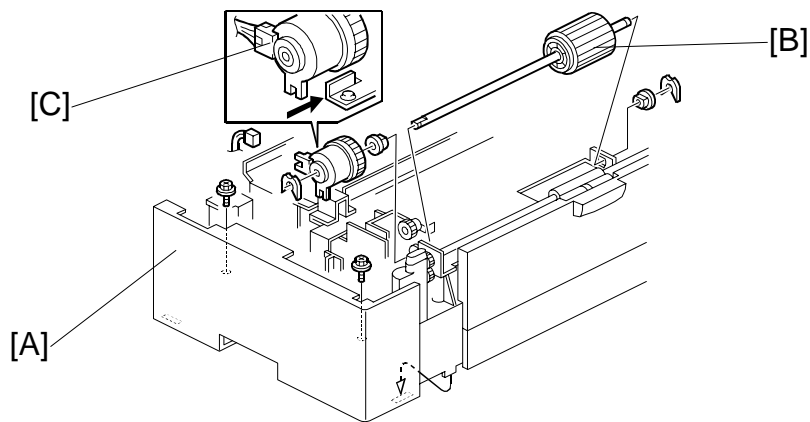

H545R501.WMF

Replacement
Adjustment

First, remove the mainframe, then remove the Right Cover [A].

B: Paper Feed Roller (2 plastic clips, 2 bushings)

C: Paper Feed Clutch (1 connector)

NOTE: Make sure that the paper feed roller shaft rotates clockwise when viewed from the right of the machine.

6.10.3 CONNECTOR

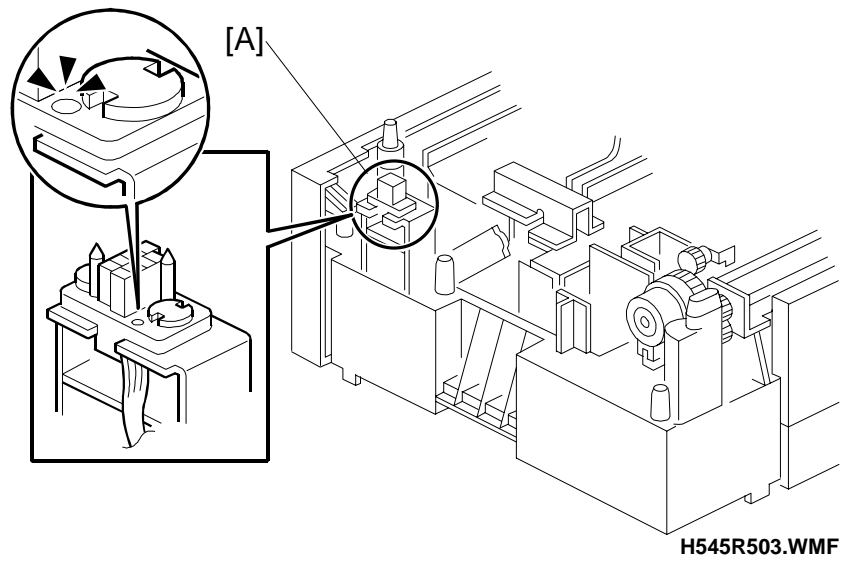

H545R503.WMF

A: Connector (2 clips)

NOTE: When installing the connector [A], the side with the small hole must face the outside of the machine.

6.11 IMAGE ADJUSTMENT

6.11.1 OVERVIEW

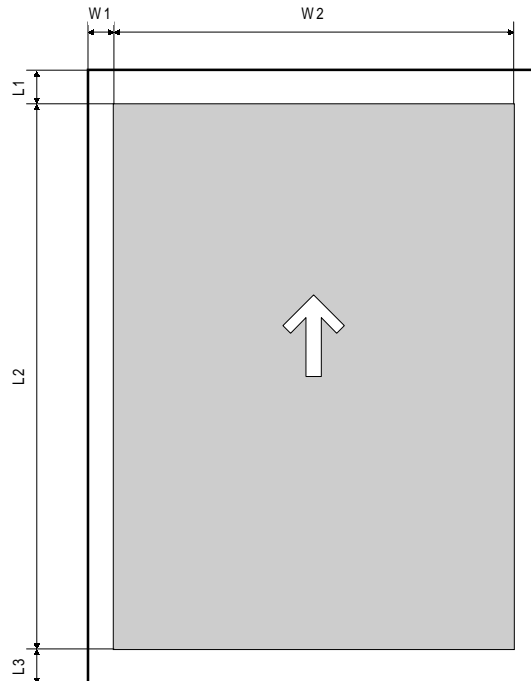

H545R650.WMF

This section explains how to adjust the scanning and printing parameters. Among these are the margin parameters shown in the diagram below, which are named in accordance with the following table.

Replacement Adjustment

Parameters	Description	Adjustable by	
		Scanning	Printing
W1	Left margin	Adjustable	Adjustable
W2	Print/Scan width	Not adjustable	Not adjustable
L1	Top margin	Adjustable	Adjustable
L2	Print/Scan length	Not adjustable	Not adjustable
L3	Bottom margin	Adjustable	Not adjustable

⚠ CAUTION

The factory settings may not be the same as the “Initial settings” described in the following procedures. The RAM reset level 0 will reset all the scan and print margin parameters to the “Initial settings.”

6.11.2 SCANNER PARAMETERS

1. Contrast

	Text Mode		Halftone Mode	
	Address	Initial Setting	Address	Initial Setting
Auto	80061E	0F(H)	800622 (Copy and Fax)	0C(H)
Normal	800620	0F(H)	800624 (PC scan)	0C(H)
Lighten	800621	13(H)	800625 (PC scan)	0E(H)
Darken	80061F	0B(H)	800623 (PC scan)	0A(H)

2. Margins

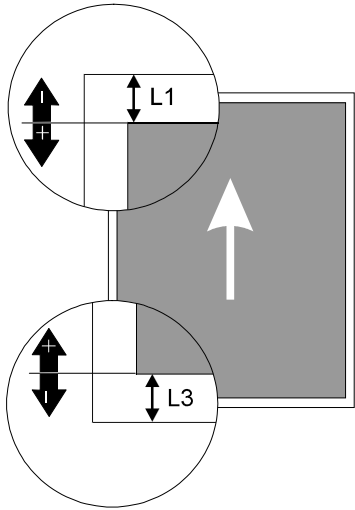
Parameter	Formula	RAM Address	Unit	Initial Setting
W1	This parameter changes the main scan start bit. To increase the margin by X mm: New setting = Current setting + X/0.5 To decrease the margin by X mm: New setting = Current setting - X/0.5	8002BF(H)	0.5 mm	7F(H)
W2	Not adjustable			
L1	 <p style="text-align: center;">H545R651.WMF</p> <p>This parameter changes the number of scanner motor steps after the scan line sensor is activated. To increase the margin by x mm: New setting = Current setting + 7.7x To decrease the margin by x mm: New setting = Current setting - 7.7x</p>	8002B6(H) (low) 8002B7(H) (high)	$\frac{1}{7.7} \text{ mm}$	59(H) [89(D)]

Parameter	Formula	RAM Address	Unit	Initial Setting
L2	Not adjustable			
L3	This parameter changes the number of scanner motor steps after the scan line sensor is activated. To increase the margin by x mm: New setting = Current setting + 7.7x To decrease the margin by x mm: New setting = Current setting - 7.7x	8002B8(H) (low) 8002B9(H) (high)	$\frac{1}{7.7} \text{ mm}$	9B(H) [155(D)]

6.11.3 PRINTER PARAMETERS

1. Margins (Main Scan Direction)

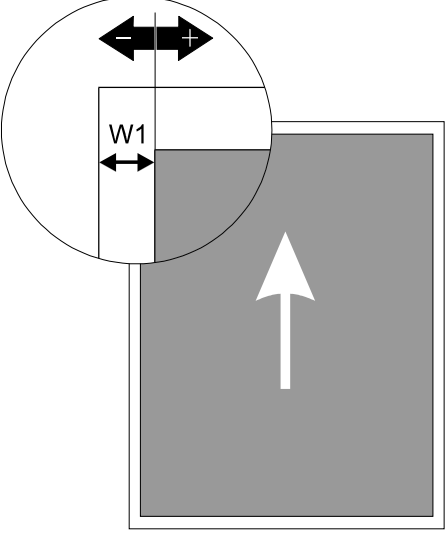
Parameter	Formula	RAM Address	Unit	Initial Setting
W1	 <p style="text-align: center;">H545R648.WMF</p> <p>To increase the margin by x mm: New setting = Current setting + x/0.5 (or 0.34) To decrease the margin by x mm: New setting = Current setting - x/0.5 (or 0.34) When the user sets the margin in the main scan direction with a User Function, the margin is added to this setting.</p>	Standard cassette: 80036B(H) Optional paper feed unit: 80036C(H) Optional multi-purpose feeder: 800370(H)	0.5 mm (Fax) 0.34 mm (printer)	08(H) 08(H) 07(H)
W2	Not adjustable			

Replacement Adjustment

2. Margins (Sub Scan Direction)

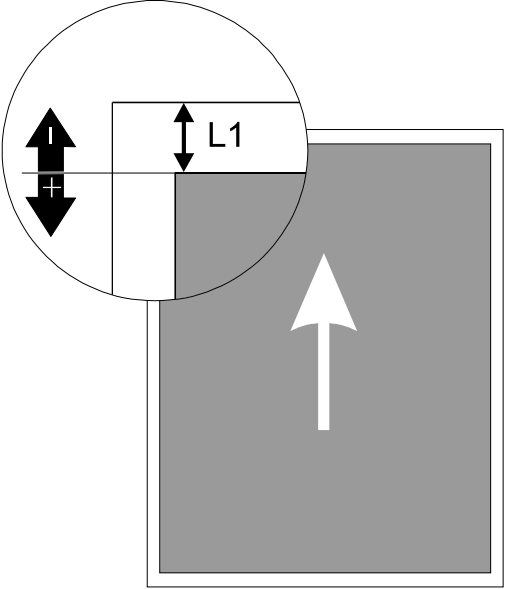
Parameter	Formula	RAM Address	Unit	Initial Setting
<p>L1</p>	 <p style="text-align: center;">H545R562.WMF</p> <p>To increase the margin by x mm: New setting = Current setting + x/0.46 To decrease the margin by x mm: New setting = Current setting - x/0.46 When the user sets the margin in the sub-scan direction with a User Function, the margin is added to this setting.</p>	<p>Standard cassette: 80035F(H)</p> <p>Optional paper feed unit: 800360(H)</p> <p>Optional multi purpose feeder: 800364(H)</p>	<p>0.46 mm</p>	<p>0B(H)</p> <p>0B(H)</p> <p>0B(H)</p>
<p>L2</p>	<p>Not adjustable</p>			
<p>L3</p>	<p>Not adjustable</p>			

6.11.4 SCANNER VIDEO PROCESSING PARAMETERS

The tables in the following pages show the video processing parameter settings for each scanning mode.

One byte of parameters is assigned for each mode (text or halftone), and they all have the same definitions as follows:

MTF / Edge detection / Edge enhancement

Bit No.	FUNCTION	COMMENTS
0-3	Not used	
4	MTF 0: On 1: Off	This bit is for text mode only. 0: Enhances the thickness of thin lines and dots, but also makes dust more obvious. 1: Thin lines may not reproduce clearly.
5	Edge enhancement 0: Off 1:On	This bit is for halftone mode only. 0: Suitable for photo originals. 1: Suitable for originals with photo and text. The edges of text become much sharper, but moire might appear in photo areas.
6	Edge detection 0: On 1: Off	This bit is for halftone mode only. 0: Suitable for most photo originals. 1: The image becomes lighter, and thin lines become paler.
7	Not used	Do not change the setting.

Mode		Address	Bit7	Bit6	Bit5	Bit4	Bit3	Bit2	Bit1	Bit0
Text	Auto on	800626H	0	1	0	0	0	0	0	0
	Auto off	80062AH	0	1	0	0	0	0	0	0
Halftone		80062EH	1	0	0	0	1	1	1	1

Auto: Auto image density

NOTE: DO NOT change bits in the shaded part of the table.

Replacement Adjustment

MTF algorithm

Bit No.	FUNCTION	COMMENTS
0-4	Not used	
5	MTF algorithm	The "high" setting enhances the thickness of thin lines and dots more than the "low" setting, however it also makes dust more obvious.
6	Bit 6 5 Setting	
	0 0 High on main and sub scan	
	0 1 Low on main and sub scan	
	1 0 High on sub scan	
1 1 Low on sub scan		
7	Not used	Do not change the setting.

Mode		Address	Bit7	Bit6	Bit5	Bit4	Bit3	Bit2	Bit1	Bit0
Text	Auto on	800627H	1	1	0	1	0	0	0	0
	Auto off	80062BH	1	1	0	1	0	0	0	0
Halftone		80062FH	1	0	1	1	0	0	0	0

Auto: Auto image density

NOTE: DO not change bits in the shaded part of the table.

Background detection threshold

Bit No.	FUNCTION	COMMENTS
0	Not used	
1	Not used	
2	Background detection threshold 0: Low 1: High	This bit is for text mode only. 0: Suitable for originals that have dark background. 1: The thickness text is enhanced, however dust is more obvious.
3-7	Not used	Do not change the settings.

Mode		Address	Bit7	Bit6	Bit5	Bit4	Bit3	Bit2	Bit1	Bit0
Text	Auto on	800629H	1	0	0	0	0	0	0	0
	Auto off	80062DH	1	0	0	0	0	0	0	0
Halftone		800631H	1	0	0	0	0	0	0	0

Auto: Auto image density

NOTE: DO not change bits in the shaded part of the table.

7. TROUBLESHOOTING

7.1 COPY QUALITY TROUBLESHOOTING

If there is a copy quality problem that cannot be solved easily, try using the following troubleshooting procedures, while referring to the point-to-point diagram. The procedures may not be exhaustive, but they may help you to find the problem.

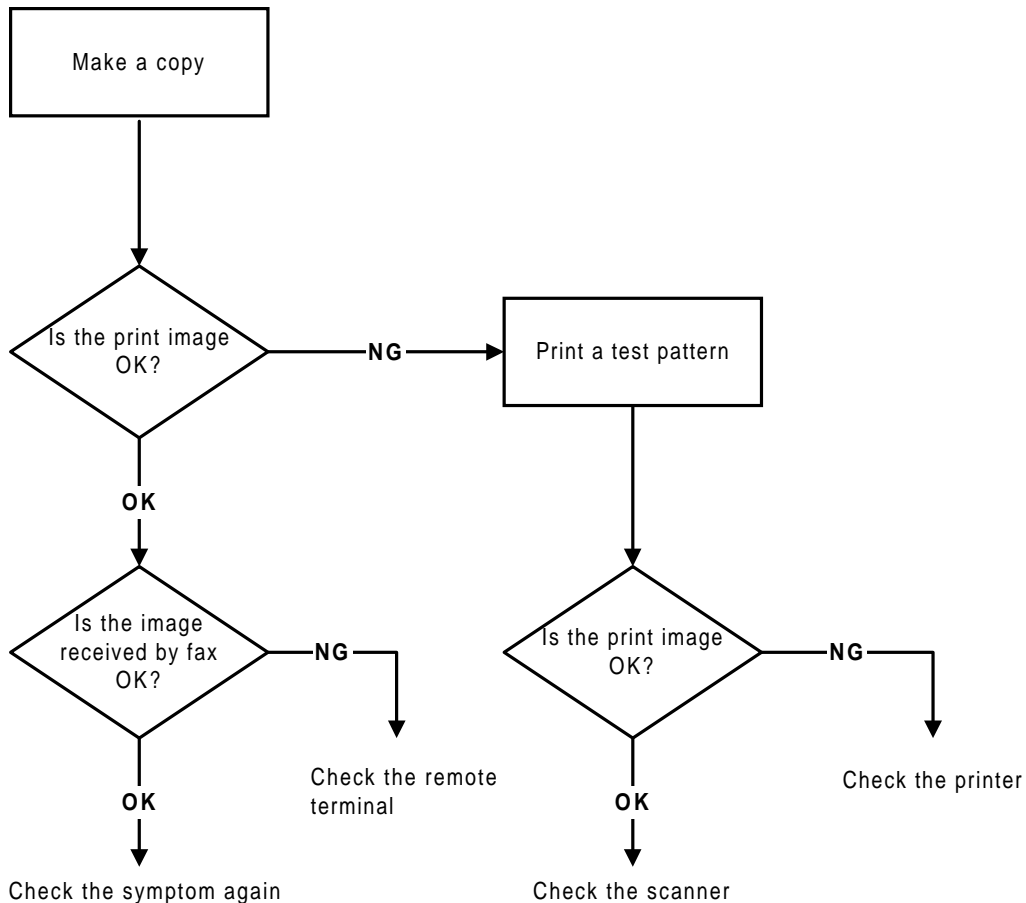

H545T501.WMF

First, distinguish whether the problem is caused by the remote terminal or by your machine. If your machine causes the problem, determine whether it is due to a scanner or printer problem.



7.1.1 BLANK COPIES

Possible Cause (Printer)

- Poor drum sensitivity.
- Laser optic components are out of position.
- The proper bias voltages are not applied to the toner application roller and/or the development roller.
- The proper current is not applied to the transfer roller.

Action:

1. Print a test pattern, and open the cover in the middle of printing.
2. Check to see if there is toner adhered to the drum surface.
If there is, do the following. If not, go to step 3.
 - Check to see if the cartridge is correctly installed.
 - Check to see if the transfer roller is correctly positioned.
3. Check if there is toner on the surface of the development roller.
If there is, do the following. If not, go to step 4.
 - Check to see if the laser optic components are properly positioned.
4. Check to see if the cartridge is empty. If it is, replace the cartridge.
If not, do the following.
 - Check the connection between the FCU (CN13) and the toner end sensor
 - Replace the toner end sensor.

7.1.2 BLACK COPIES

Possible Cause (Scanner)

- The contact image sensor is defective.

Action:

1. Check the connection between the FCU (CN8) and the contact image sensor.
2. Replace the contact image sensor.

Possible Cause (Printer)

- The charge is improperly applied.

Action:

1. Check the connections between the power pack, the charge voltage terminals, and the cartridge.
 - If they are OK, go to step 2.
 - If not, fix the connections.
2. Check the connections behind the power pack.

7.1.3 DIRTY BACKGROUND

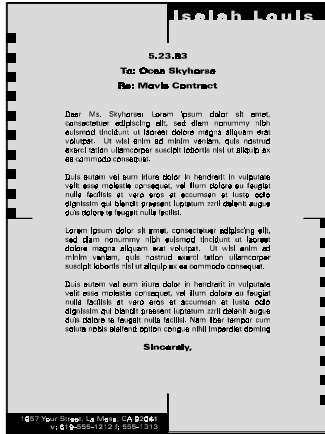

H545T502.WMF

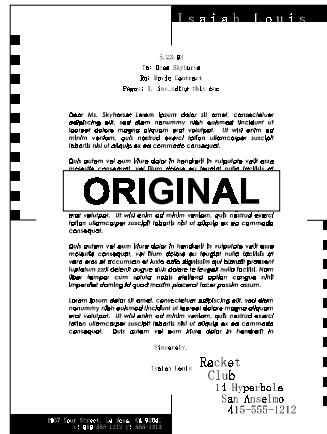

H545T503.WMF

Possible Cause (Scanner)

- Scanner shading correction error or incorrect threshold.

Action:

1. Clean the shading white roller.
2. Adjust the scanner contrast threshold settings.

Possible Cause (Printer)

- Poor drum sensitivity.
- The charge is improperly applied.
- The hot roller is dirty.

Action:

1. Try replacing the cartridge.
2. Check to see if the hot roller surface is dirty.
 - If it is, clean the roller or replace the cleaning pad.
 - If not, go to step 3.
3. Check to see if all the charge bias terminals and the cartridge.
 - If they are, check or replace the power pack.
 - If not, fix the connections.

Trouble-shooting

7.1.4 UNEVEN IMAGE DENSITY

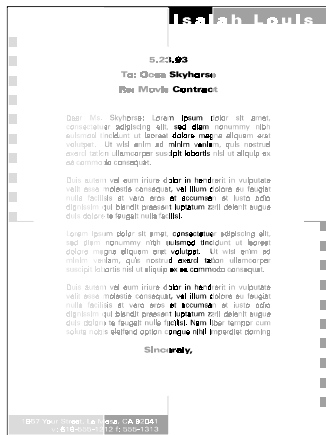

H545T504.WMF

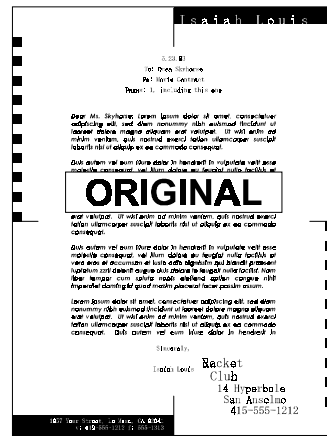

H545T503.WMF

Possible Cause (Scanner)

- Dirty exposure glass
- Partial scanner lamp defect

Action

- Clean the exposure glass of the image sensor.
- Replace the image sensor.

Possible Cause (Printer)

- Poor drum sensitivity.
- Dirty laser optic components.
- A deformed toner metering blade.
- Uneven toner supply in the toner hopper.

Action:

1. Print a solid black test pattern, and open the cover in the middle of printing.
2. If the image is lighter in the center of the image, the toner may be low. Replace the cartridge. If it is not, go to step 3.
3. Check to see if the toner is evenly distributed on the drum.
 - If it is not, check the cartridge and the laser optic components.
 - If it is, check if there is any dirt on the transfer roller surface.

7.1.5 VERTICAL BLACK LINES

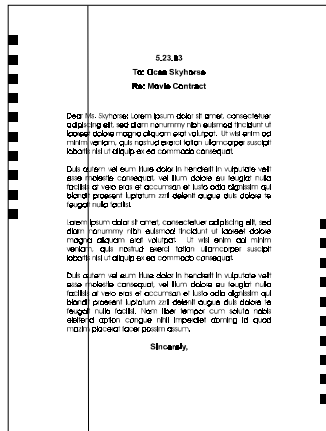

H545T505.WMF

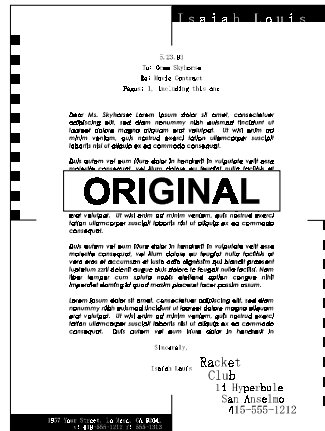

H545T503.WMF

Possible Cause (Scanner)

- Defective contact image sensor element(s).
- Dirt or dust on the exposure glass.
- Dirty white roller in the ADF.

Action:

1. Clean the exposure glass and the shading white roller.
2. Replace the contact image sensor.

Possible Cause (Printer)

- Damaged cleaning blade.
- Dirty hot roller stripper(s).

Action:

1. Replace the cartridge.
2. Clean the hot roller strippers.



7.1.6 HORIZONTAL BLACK LINES

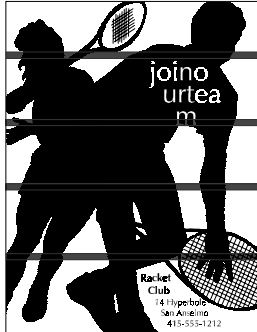

H545T506.WMF



H545T507.WMF

Possible Cause (Printer)

- The drum surface is scratched or damaged.

Action:

1. Check to see if the surface of the drum is damaged.
 - Change the cartridge if damaged.

7.1.7 VERTICAL WHITE LINES

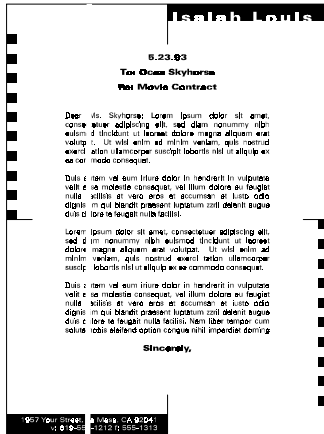

H545T508.WMF

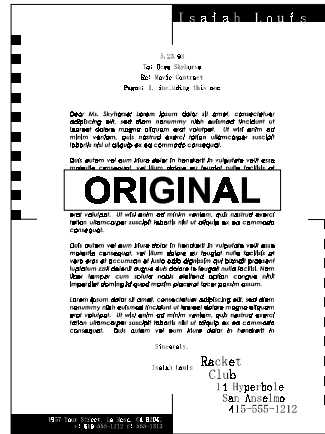

H545T503.WMF

Possible Cause (Scanner)

- Defective image sensor element(s).

Action:

- Replace the image sensor.

Possible Cause (Printer)

- The laser optic components are dirty.
- The hot roller stripper scrapes off toner from the print paper.
- Damaged cleaning blade.

Action:

- Clean the laser optic components.
- Check the hot roller stripper mechanism. Clean the strippers and replace them if damaged.
- Replace the cartridge.



7.1.8 HORIZONTAL WHITE LINES

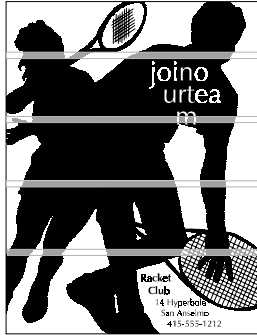

H545T509.WMF



H545T511.WMF

Possible Cause (Printer)

- A damaged or deformed development roller surface.
- The development bias is unstable.
- The transfer current is unstable.

Action:

1. Print a test pattern, and open the cover in the middle of printing.
2. Check to see if horizontal white lines (where toner is not adhered) appear on the drum surface or not.
 - If not, check the transfer roller surface and the transfer bias terminal connections. If they are OK, check or replace the power pack.
 - Change the cartridge.

7.1.9 BLACK DOTS/SPOTS

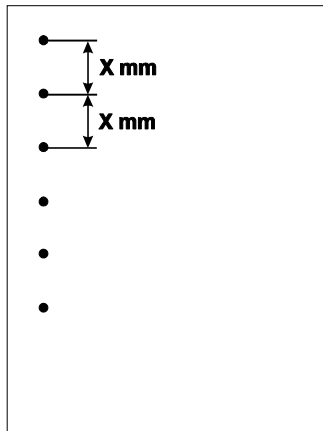

H545T510.WMF

Possible Cause (Scanner)

- Dust on the exposure glass.

Action:

- Clean the exposure glass.
- Try disabling MTF.

Possible Cause (Printer)

- The drum surface is damaged (this is likely if the dots appear at 75.4 mm intervals).

Action:

- Replace the cartridge.

Trouble-
shooting

7.1.10 WHITE SPOTS IN BLACK IMAGE AREAS

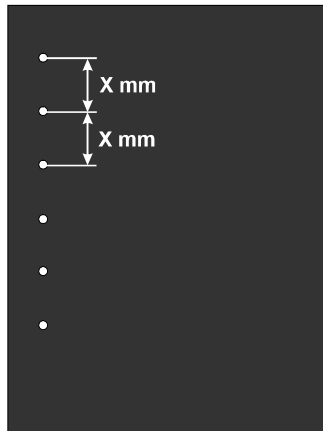

H545T501.WMF

Possible Cause (Printer)

- The drum surface is damaged (this is likely if the dots appear at 75.4 mm intervals).
- The development roller surface is damaged (this is likely if the dots appear at 36.7 mm intervals).
- The toner application roller surface is damaged (this is likely if the dots appear at about 28.5 mm intervals).

Action:

- Replace the cartridge.

7.1.11 FAINT COPIES

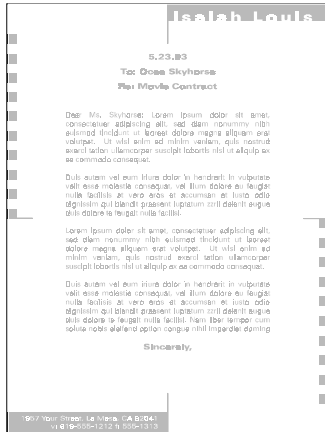

H545T504.WMF

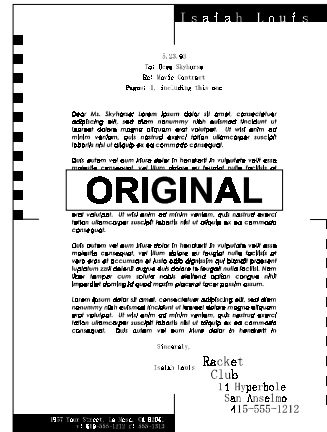

H545T512.WMF

Possible Causes (Scanner)

- Dirty shading plate and/or exposure glass
- Incorrect scan threshold
- Contact image sensor (LED, sensor element) defect

Action:

- Clean the white roller in the ADF.
- Adjust the scan threshold settings.
- Replace the image sensor.

Possible Causes (Printer)

- Poor drum sensitivity.
- Dirty laser optic components.
- Incorrect development/ transfer bias
- Low toner
- Low fusing temperature

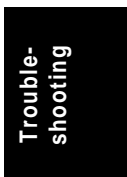

Action:

1. Print a test pattern, and open the cover in the middle of printing.
2. Check to see if the toner on the paper at the entrance of the fusing unit appears faint.
 - If it does, check or replace the fusing lamp, thermistor, and PSU.
 - If it does not, go to step 3.
3. Check to see if the toner on the drum looks faint.
 - If it does, go to step 4.
 - If it does not, check the contacts between the transfer bias terminals and power pack.
4. Check all the contacts between the development and toner application rollers' bias terminals.
 - If it does not, try replacing the cartridge.

7.1.12 VERTICAL BLACK BAND

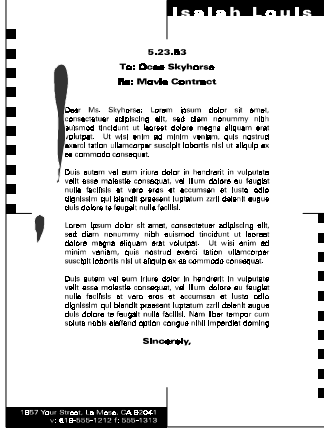

H545T505.WMF

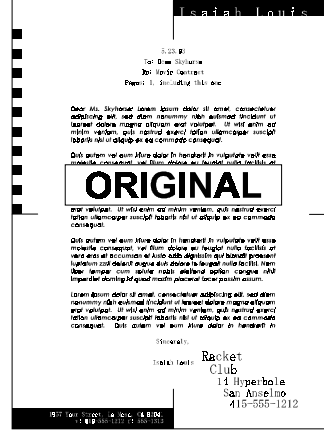

H545T512.WMF

Possible Cause (Printer)

- A deformed, damaged, or incorrectly positioned toner metering blade.

Action:

- Replace the cartridge.

7.1.13 UNFUSED COPIES

Possible Cause (Printer)

- The thermistor is defective.
- The spring mechanism for the fusing pressure roller is defective.
- Incorrect toner type.
- Non-recommended paper type.

Action:

1. Check to see if the correct type of paper and toner are in use.
 - If it is, go to step 2.
 - If not, use recommended types of paper and toner.
2. Try replacing the fusing lamp and the hot and/or pressure roller.

7.1.14 GHOST IMAGE

Possible Cause (Printer)

- Poor drum sensitivity.
- The cleaning blade is deformed or incorrectly positioned.
- Dirty hot roller

Action:

- Replace the cartridge.
- Clean the hot roller surface and/or replace the cleaning pad.

7.1.15 TONER ON THE BACK OF THE PRINTER PAPER

Possible Cause (Printer)

- Dirty transfer roller
- Dirty fusing pressure roller

Action:

1. Check to see if the transfer roller is dirty with toner.
 - If it is, clean the roller surface by copying a sheet of white paper three times or more. (For better results, copy one sheet at a time)
 - If not, go to step 2.
2. Check to see if the fusing pressure roller is dirty with toner.
 - If it is, clean the fusing pressure roller.
 - If not, check for any other dirty rollers and clean them.

7.1.16 INCORRECTLY ALIGNED OUTPUT (DATA SHIFTED TO THE RIGHT OR LEFT)

Possible Cause (Scanner)

- Incorrect setting of the document guide.

Action:

- Align each side of the document with the document guides.

Possible Cause (Printer)

- Laser optics are aligned incorrectly.
- Improper print margin setting (main scan direction).

Action:

- Adjust the main scan print margin. (Refer to Section 6-12.)
- Check that the laser optics are aligned correctly.

7.1.17 INCORRECTLY ALIGNED OUTPUT (IMAGE SHIFTED VERTICALLY)/REDUCED IMAGE

Possible Cause:

- Improper print margin (sub-scan direction).
- Dirty registration roller.

Action:

- Adjust the sub-scan print margin. (Refer to Section 6-12.)
- Clean the registration roller.

7.2 MECHANICAL PROBLEMS

7.2.1 ADF/SCANNER

1. Non Feed

Possible Cause:

- Use of the incorrect document type or size.
- The operation panel is not closed properly.
- The pick-up rollers and feed belt are dirty or worn out.
- The mechanical clutch mechanism for document pick-up is defective.
- Incorrect positioning of the separation roller.
- The scanner motor is defective.

Action:

1. Check whether a correct document type is being used.
2. Check that the operation panel is closed securely.
3. If the problem remains, do the following:
 - Clean the pick-up rollers and feed belt with a soft cloth and water, and replace them if damaged.
 - Check the connection between the FCU (CN14) and the scanner motor.
 - Replace the scanner motor.

2. Jam

Possible Cause:

- Incorrect document type or size.
- The document is too long.
- The scanner rollers (pick-up, feed, R1, and R2 rollers) are dirty.
- Obstruction in the document paper path.
- The scan line sensor is defective.
- Defective scanner motor

Action:

1. Check whether a correct document type is being used, and that the document length is within the maximum limit.
2. Check for obstructions in the paper path.
3. If the problem remains, do the following.
 - Clean the rollers with a soft cloth and water, and replace them if damaged.
 - Check that the scan line sensor is working correctly.
 - Replace the scanner motor.

3. Skew

Possible Cause:

- Incorrect document type or size.
- The document guide is set incorrectly.
- The operation panel is not closed properly.
- The scanner rollers (pick-up, feed, R1, and R2 rollers) are dirty.
- Obstruction in the document paper path.
- The separation roller is out of position.

Action:

1. Check whether a correct document type is being used.
2. Check that the operation panel is closed securely and that the document guide is set properly.
3. Check for obstructions in the paper path.
4. If the problem remains, do the following.
 - Check that the separation roller is set properly. Replace it if damaged.
 - Clean the rollers with a soft cloth and water, and replace them if damaged.

4. Multi-feed

Action:

- Clean or replace the separation roller.

7.2.2 PRINTER

1. Non-feed

Possible Cause:

- Use of a non-recommended paper type.
- The paper cassette end fence is set incorrectly.
- The paper lift mechanism is not working properly.
- Malfunction in the paper feed clutch.
- The paper feed roller is set incorrectly.
- The paper feed motor is defective.
- The registration sensor and/or paper edge sensor is defective.

Action:

1. Check whether a correct paper type is being used.
2. Check that the paper cassette end fence is set correctly and check the paper lift mechanism.
3. Check that the feed clutch for the cassette is working properly.
4. Check that the paper feed roller is installed properly. Clean or replace if necessary.
5. Check the registration roller and its mechanism. Clean or replace if necessary.
6. Check that the registration sensor and paper edge sensor are working correctly.
7. If the problem remains, do the following:
 - Check the connections between the FCU (CN16) and the paper feed motor.
 - Replace the paper feed motor.

2. Paper Jam - Inside Printer

Possible Cause:

- Using a non-recommended type of paper.
- The paper end fence and/or the paper guides in the cassette are set incorrectly.
- The registration roller is dirty.
- The registration sensor and/or paper edge sensor is defective.
- Obstruction in the paper path.
- The main motor is defective.

Action:

1. Check whether a correct paper type is being used, and whether the paper end fence and guides are set correctly.
2. Check for obstructions in the paper path.
3. Check the registration roller and its mechanism. Clean or replace if necessary.
4. Check that the registration sensor and paper edge sensor are working properly.
5. If the problem remains, do the following:
 - Check the connections between the FCU (CN15) and the main motor.
 - Replace the main motor.
 - Check the FCU output of power (CN15-2, 5) and drive (CN15-1, 3, 4, 6) signals to the main motor. If signals are not output, replace the FCU.
 - Check the fusing unit drive mechanism. Check to see that the gears are installed correctly.

3. Jam - Fusing Exit

Possible Cause:

- Use of a non-recommended type of paper.
- Obstruction in the paper path.
- The registration sensor is defective.
- Malfunction in the fusing drive mechanism.
- The paper feed-out sensor is defective.
- Malfunction in the hot roller stripper(s) mechanism.
- Malfunction in the pressure mechanism in the fusing unit.

Action:

1. Check whether a correct type of paper is being used.
2. Check for obstructions in the paper path.
3. Check that the registration sensor is working correctly.
4. Check all the gears in the fusing drive mechanism.
5. Check that the fusing exit sensor is working correctly.
6. Check the hot roller strippers and the pressure mechanism in the fusing unit.

4. Skew

Possible Cause:

- Use of a non-recommended type of paper.
- Incorrect positioning of the paper guides in the paper cassette.
- The separation pad is out of position.
- The paper feed roller is worn out or damaged.
- Obstruction in the paper path.
- Malfunction in the registration mechanism.

Action:

1. Check whether a correct type of paper is being used.
2. Check that the paper guides and the end fence are set correctly.
3. Check that the separation pad is set correctly.
4. Check if the paper feed roller is installed correctly and clean. Replace if necessary.
5. Check for obstructions in the paper path.
6. Check the registration mechanism and clean or replace the rollers if necessary.

5. Multi-feed

Possible Cause:

- Use of a non-recommended type of paper.
- Incorrect positioning of the paper guides and/or end fence in the paper cassette.
- The separation pad is out of position.

Action:

1. Check whether a correct type of paper is being used.
2. Check that the paper guides and the end fence are set correctly.
3. Check that the separation pad is set correctly.

7.3 SERVICE CALL CONDITIONS

If the Call Service indicator is lit, one of the following conditions has occurred:

Symptom	Error Code	Sub-code	SC-code
Laser diode failure	9-20	21	2-21
Fusing unit failure (fusing lamp at high temperature during printing)	9-22	01	0-01
Fusing unit failure (fusing lamp not at printing temperature after warm-up)	9-22	02	0-02
Fusing unit failure (fusing lamp at high temperature in power saver mode)	9-22	03	0-03
Fusing unit failure (fusing lamp at high temperature in power saver mode)	9-22	04	0-04
Fusing unit failure (fusing lamp at low temperature in power saver mode)	9-22	05	0-05
Fusing unit failure (fusing lamp at low temperature during printing)	9-22	07	0-07
Fusing unit failure (fusing lamp at an extremely high temperature)	9-22	08	0-08
Fusing unit failure (thermistor error)	9-22	09	0-09
Fusing unit failure (fusing lamp at high temperature in energy saver mode)	9-22	0A	0-0A
The machine detects that both jumper 63 and jumper 64 on the FCU are shorted.	9-22	0B	0-0B
Hexagonal mirror motor startup error	9-23	31	3-31
Hexagonal mirror motor error while printing	9-23	32	3-32
Power pack failure (development roller bias too high)	9-29	51	5-51
Power pack failure (charge brush roller bias too high)	9-29	52	5-52
Power pack failure (transfer roller bias too high)	9-29	53	5-53
Power pack failure (development roller too low)	9-29	54	5-54
Power pack failure (charge brush roller bias too low)	9-29	55	5-55
Power pack failure (transfer roller bias too low)	9-29	56	5-56
Power pack failure (incorrect bias for development and toner application rollers)	9-29	57	5-57
Power pack failure (incorrect bias for development and toner application rollers)	9-29	58	5-58
Power pack failure (incorrect bias for transfer roller)	9-29	59	5-59

To find out which problem has occurred, either:

- See the Auto Service Call report sent to the service station by the machine. This report lists a sub-code, as well as the error message; this sub-code may help you find the problem.
Alternatively, check the sub-code stored at RAM address 8003C7(H).
- Check the error code history using service function 03.
- Try to clear the service call condition (for failures which are not related to the fusing unit): switch the power off, wait 10 seconds, then switch it back on (for fusing unit errors, set printer switch 01 bit 0 to 1 before switching the machine off)
- The LCD panel displays an SC code when the error occurs.

After each troubleshooting attempt, reset the machine and try to operate it. If the machine still does not work, continue troubleshooting.

7.4 ERROR CODES

If an error code occurs, re-send the fax or have the end user send a fax back to you as the problem dictates. If the same problem occurs, try to fix the problem as suggested below. Note that error codes 4-00, 01, 02, and 10 only appear in the error code display and the service report.

Code	Meaning	Suggested Cause/Action
0-00	DIS/NSF not detected within 40 seconds of pressing Start	Check the line connection. Check the NCU - FCU connectors. The machine at the other end may be incompatible. Replace the NCU or FCU. Check for DIS/NSF with an oscilloscope. If the RX signal is weak, it may be a bad line.
0-01	DCN received unexpectedly	The other party is out of paper or has a jammed printer. The other party pressed Stop during communication.
0-03	Incompatible modem at the other end	The other terminal is incompatible.
0-04	CFR or FTT not received after modem training	Check the line connection. Check the NCU - FCU connectors. Try changing the TX level and/or cable equalizer settings. Replace the FCU or NCU. The other terminal may be faulty; try sending to another machine. If the RX signal is weak or defective, there may be a bad line. Cross-reference TX level - NCU Parameter 01 (PSTN), RAM 807FB7 (PABX) Cable equalizer - G3 Switch 07 (PSTN), G3 Switch 08 (PABX) Dedicated TX parameters - Section 4-4
0-05	Unsuccessful after modem training at 2400 bps	Check the line connection. Check the NCU - FCU connectors. Try adjusting the TX level and/or cable equalizer. Replace the FCU or NCU. Check for line problems. Cross-reference See error code 0-04.

Code	Meaning	Suggested Cause/Action
0-06	The other terminal did not reply to DCS	<p>Check the line connection. Check the FCU - NCU connectors. Try adjusting the TX level and/or cable equalizer settings. Replace the NCU or FCU. The other end may be defective or incompatible; try sending to another machine. Check for line problems. Cross-reference See error code 0-04.</p>
0-07	No post-message response from the other end after a page was sent	<p>Check the line connection. Check the FCU - NCU connectors. Replace the NCU or FCU. The other end may have jammed or run out of paper. The other end user may have disconnected the call. Check for a bad line. The other end may be defective; try sending to another machine.</p>
0-08	The other end sent an RTN or PIN after receiving a page, because there were too many errors	<p>Check the line connection. Check the FCU - NCU connectors. Replace the NCU or FCU. The other end may have jammed, or run out of paper or memory space. Try adjusting the TX level and/or cable equalizer settings. The other end may have a defective modem/NCU/FCU; try sending to another machine. Check for line problems and noise. Cross-reference TX level - NCU Parameter 01 (PSTN), RAM 807FB7 (PABX) Cable equalizer - G3 Switch 07 (PSTN), G3 Switch 08 (PABX) Dedicated TX parameters - Section 4-4</p>
0-14	Non-standard post-message response code received	<p>Check the FCU - NCU connectors. Incompatible or defective remote terminal: try sending to another machine. Noisy line: re-send. Try adjusting the TX level and/or cable equalizer settings. Replace the NCU or FCU. Cross-reference: See error code 0-08.</p>
0-15	The other terminal is not capable of a certain function	The other terminal does not have the SEP or SUB function.
0-17	Pressing the Stop key interrupts communication.	If the Stop key was not pressed and this error keeps occurring, replace the operation panel or OPU.

Code	Meaning	Suggested Cause/Action
0-20	Facsimile data not received within 6 seconds of retraining	Check the line connection. Check the FCU - NCU connectors. Replace the NCU or FCU. Check for line problems. Try calling another fax machine. Try adjusting the reconstruction time for the first line and/or RX cable equalizer setting. Cross-reference Reconstruction time - G3 Switch 0A, bit 6 RX cable equalizer - G3 Switch 07 (PSTN), G3 Switch 08 (PABX)
0-21	EOL signal (end-of-line) from the other end not received within 5 seconds of the previous EOL signal	Check the connections between the FCU, NCU, & line. Check for line noise or other line problems. Replace the NCU or FCU. The remote machine may be defective or may have disconnected. Cross-reference Maximum interval between EOLs and ECM frames - G3 Bit Switch 0A, bit 4
0-22	The signal from the other end was interrupted for more than the acceptable modem carrier drop time (default: 0.2 seconds)	Check the line connection. Check the FCU - NCU connectors. Replace the NCU or FCU. Defective remote terminal. Check for line noise or other line problems. Try adjusting the acceptable modem carrier drop time. Cross-reference Acceptable modem carrier drop time - G3 Switch 0A, bits 0 and 1
0-23	Too many errors during reception	Check the line connection. Check the FCU - NCU connectors. Replace the NCU, FCU. Defective remote terminal. Check for line noise or other line problems. Try asking the other end to adjust their TX level. Try adjusting the RX cable equalizer setting and/or RX error criteria. Cross-reference RX cable equalizer - G3 Switch 07 (PSTN), G3 Switch 08 (PABX) RX error criteria - Communication Switch 02, bits 0 and 1
0-24	Printer failure occurred while the memory was full during non-ECM reception; negative response returned	There is no memory space available, or substitute reception is disabled. Try asking the user to add optional extra memory.
0-29	Data block format failure in ECM reception	Check for line noise or other line problems. Try receiving from another machine. Replace the FCU.

Code	Meaning	Suggested Cause/Action
0-30	The other terminal did not reply to NSS(A) in AI short protocol mode	Check the line connection. Check the FCU - NCU connectors. Try adjusting the TX level and/or cable equalizer settings. The other terminal may not be compatible. Cross-reference Dedicated TX parameters - Section 4-4
0-52	Polarity changed during communication	Check the line connection. Retry the communication.
0-70	Communication mode specified CM/JM and it was not available. (V.8 calling and called terminal)	The other terminal did not have a compatible communication mode (e.g., the other terminal was a V.34 data modem.) A polling TX file was not ready at the other terminal when the calling terminal initiated polling RX.
0-74	The calling terminal fell back to T.30 mode, because it could not detect ANSam after sending CI.	The calling terminal could not detect ANSam due to noise, etc. ANSam was too short to detect. Check the line connection and condition. Try receiving a call from another V.8/V.34 fax.
0-75	Calling terminal fell back to T.30 mode, because it could not detect CM in response to ANSam. (ANSam time out)	The terminal could not detect ANSam. Check the line connection and condition. Try receiving a call from another V.8/V.34 fax.
0-76	The calling terminal fell back to T.30 mode, because it could not detect JM in response to CM. (CM time out)	The called terminal could not detect JM due to noise, etc. Check the line connection and condition. Try making a call to another V.8/V.34 fax.
0-77	The calling terminal fell back to T.30 mode, because it could not detect CJ in response to JM. (JM time out)	The calling terminal could not detect JM due to noise, etc. A network that has narrow bandwidth cannot pass JM to the other end. Check the line connection and condition. Try receiving a call from another V.8/V.34 fax.
0-79	Called terminal detected CI while waiting for a V.21 signal.	Check for line noise or other line problems. If this error occurs, the called terminal falls back to T.30 mode.

Code	Meaning	Suggested Cause/Action
0-80	The time out in V.34 phase 2 (line probing) disconnected the line.	The guard timer expired while starting these phases. Serious noise, narrow bandwidth, or low signal level can cause these errors.
0-81	Line was disconnected due to time out in V.34 phase 3 (equalizer training).	If these errors happen at the transmitting terminal: Try making a call later.
0-82	The time out in V.34 phase 4 (control channel start-up) disconnected the line.	Try using V.17 or a slower modem with dedicated TX parameters. Try increasing the TX level.
0-83	The time out in the V.34 control channel restart sequence disconnected the line.	Try adjusting the cable equalizer setting. If these errors happen at the receiving terminal: Try adjusting the cable equalizer setting. Try increasing the TX level. Try using V.17 or a slower modem if the same error is frequent when receiving from multiple senders.
0-84	Abnormal signaling in V.34 phase 4 (control channel start-up) disconnected the line.	The signal did not stop within 10 seconds. Turn off the machine, then turn it back on. If the same error is frequent, replace the FCU.
0-85	Abnormal signaling in V.34 control channel restart disconnected the line.	The signal did not stop within 10 seconds. Turn off the machine, then turn it back on. If the same error is frequent, replace the FCU.
0-86	The line was disconnected because the other terminal requested a data rate using MPh that was not available in the currently selected symbol rate.	The other terminal was incompatible. Ask the other party to contact the manufacturer.
0-87	The control channel started after an unsuccessful primary channel.	The receiving terminal restarted the control channel because data reception in the primary channel was not successful. This does not result in an error communication.
0-88	The line was disconnected because PPR was transmitted/received 9 (this is the default) times within the same ECM frame.	Try using a lower data rate at the start. Try adjusting the cable equalizer setting.
1-00	Document jam	Incorrectly inserted document or unsuitable document type. Check the ADF drive components and sensors. Cross-reference ADF mechanical problems - Section 7-2-1
1-01	Document length exceeded the maximum	Try changing the maximum acceptable document length. Divide the document into smaller pieces. Check the ADF drive components and sensors. Cross-reference Max. document length - Scanner switch 00, bits 2 and 3 ADF mechanical problems - Section 7-2-1

Code	Meaning	Suggested Cause/Action
1-10	Paper at the scan line when the power was turned on.	Remove the document. Check the scan line sensor. Cross-reference ADF mechanical problems - Section 7-2-1
1-17	Document jam in the feed-out area	Clear any debris from the sensor actuator. Check the ADF drive components and sensors. Cross-reference ADF mechanical problems - Section 7-2-1
1-20	Paper did not reach the fusing exit at the end of printing	Remove the paper. Check the printer drive components and sensors. Cross-reference Printer mechanical problems - Section 7-2-2
1-21	Paper present at the fusing exit after printing	Remove the paper. Check the printer drive components and sensors. Cross-reference Printer mechanical problems - Section 7-2-2
1-30	Paper ran out during printing	Add paper in the cassette.
1-34	Paper ran out after printing	Add paper in the cassette.
1-71	The cover was opened or the cassette was pulled out during printing	Close the cover or put back the cassette.
2-10	The modem cannot enter TX mode	Replace the FCU.
2-11	Only one V.21 connection flag was received	Change the FCU.
2-12	Modem clock irregularity	Replace the FCU.
2-20	Abnormal coding/decoding (CPU not ready)	Replace the FCU.
2-50	The machine reset itself	Replace the FCU.
4-10	Communication failed because of Tel. No./CSI mismatch (Protection against Wrong Connections)	Reprogram the CSIs correctly, then re-send. The machine at the other end may be defective.
5-00	Data reconstruction not possible	Replace the FCU.
5-10	DCR timer expired	Replace the FCU.
5-20	Storage impossible because of a lack of memory	Temporary memory shortage. Replace the FCU or optional IC card.
5-21	Memory overflow	
5-22	Mode table overflow after the second page of a scanned document	Wait for the messages that are currently in the memory to be sent, or delete some files from memory.

Code	Meaning	Suggested Cause/Action
5-23	Print data error when printing a substitute RX or confidential RX message	Ask the other end to re-send the message. Replace the FCU or IC memory card.
5-24	Memory overflow after the second page of a scanned document	Try using a lower resolution setting. Wait for the messages that are currently in the memory to be sent, or delete some files from memory.
5-25	SAF file access error	Replace the FCU or IC memory card.
5-30	Mode table for the first page to be printed was not effective	Replace the FCU or IC memory card.
6-00	G3 ECM – T1 time out during reception of facsimile data	Try adjusting the RX cable equalizer. Replace the FCU or NCU.
6-01	G3 ECM - no V.21 signal was received	
6-02	G3 ECM - EOR was received	
6-03	G3 ECM - non-standard V.21 code received	The other terminal may be defective.
6-04	G3 ECM - RTC not detected	Check the line connection. Check connections from the NCU to the FCU. Check for a bad line or defective remote terminal. Replace the FCU or NCU.
6-05	G3 ECM - facsimile data frame not received within 18 seconds of CFR, but there was no line fail	Check the line connection. Check connections from the NCU to the FCU. Check for a bad line or defective remote terminal. Replace the FCU or NCU. Try adjusting the RX cable equalizer Cross-reference RX cable equalizer - G3 Switch 07 (PSTN), G3 Switch 08 (PABX)
6-06	G3 ECM - coding/decoding error	Defective FCU. The other terminal may be defective.
6-08	G3 ECM - PIP/PIN received in reply to PPS.NULL	The other end pressed Stop during communication. The other terminal may be defective.
6-09	G3 ECM - ERR received	Check for a noisy line. Adjust the TX levels of the communicating machines. See code 6-05.
6-10	G3 ECM - error frames still received at the other end after all communication attempts at 2400 bps	Check for line noise. Adjust the TX level (use NCU parameter 01 or the dedicated TX parameter for that address). Check the line connection. Defective remote terminal.

Code	Meaning	Suggested Cause/Action
6-11	G3 ECM - printing impossible because of a missing first line in the MMR coding	Check for problems in the printer mechanism.
6-21	V.21 flag detected during high speed modem communication	The other terminal may be defective or incompatible.
6-99	V.21 signal not stopped within 6 seconds	Replace the FCU.
9-07	Paper jam at the cassette entrance	If the problem persists, replace the FCU. Cross-reference Paper non-feed - Section 7-2-2 Jam at the cassette entrance – Section 7-2-2
9-08	Paper jam inside the development area	If the problem persists, replace the FCU. Cross-reference Paper jam - Section 7-2-2
9-09	Paper jam in the fusing exit area	If the problem persists, replace the FCU. Cross-reference Paper jam - Section 7-2-2
9-10	Toner end detected	Replace the cartridge.
9-12	Cover open detected during printing	Close the cover, or check the cover sensors.
9-20	Laser diode failure	If the problem persists, replace the FCU or LDDR.
9-22	Fusing lamp failure	If the problem persists, replace the FCU, fusing lamp, thermistor, or PSU.
9-23	Hexagonal mirror motor failure	If the problem persists, replace the FCU or polygonal mirror motor.
9-29	Power pack failure	If the problem persists, replace the power pack or PSU.
9-50	Optional cassette - paper non-feed	Check the paper feed mechanism and sensors. Cross-reference Printer mechanical problems - Section 7-2-2
9-51	Optional cassette - paper jam at the cassette entrance	Check the paper feed mechanism and sensors. Cross-reference Printer mechanical problems - Section 7-2-2
9-60	Printer error occurs during reception	If substitute reception is switched off and a paper jam or other printer error occurs, the machine will terminate the reception. Check the printer mechanism.
9-61	Memory overflow occurs during reception	Check the SAF.
9-84	Standard cassette – paper non-feed	Check the paper feed mechanism and sensors. Cross-reference Paper jam - Section 7-2-2



7.5 ELECTRICAL COMPONENT DEFECTS

7.5.1 DEFECTIVE SENSOR TABLE

Sensor	Status	Symptoms if Defective
Document sensor	ON	The LCD displays "CLEAR ORIGINAL" or "DIAL FAX NO" at power-up.
	OFF	The LCD still displays "SET DOC. OR DIAL NO." after a document is placed in the feeder.
Scan line sensor	ON	The LCD displays "CLEAR ORIGINAL" at power-up.
	OFF	The LCD displays "CLEAR ORIGINAL" soon after the start of copying.
Interlock switches	ON	There is no alarm on opening the cover, and the LCD does not display "CLOSE COVER".
	OFF	The LCD displays "CLOSE COVER" at power-up.
Registration sensor	ON	The LCD displays "CLEAR COPY" at power-up.
Paper edge sensor	ON	The LCD displays "CLEAR COPY" at power-up.
Fusing exit sensor	ON	The LCD displays "CLEAR COPY" soon after the start of copying.
Toner end sensor	ON	The LCD displays "SET TONER" at power-up.
Paper end sensor - standard cassette	ON	The ADD PAPER indicator lights even if paper is remaining.
Paper end sensor – paper feed unit	ON	The Add Paper indicator on the operation panel of the lower cassette lights even if paper remains.
Upper rear cover switch	ON	The LCD displays "CLOSE COVER" at power-up.
Lower rear cover switch	ON	The LCD displays "CLOSE COVER" at power-up.

7.5.2 BLOWN FUSE TABLE

The only service-replaceable fuses are the following.

Fuse	Symptoms if Defective
PSU - F1/ F2/F3	The machine does not receive power (F3 - 220V PSU only)